



7136 S Yale Ave
Suite 501
Tulsa, OK 74133

o 918.664.4581
f 918.664.3066

www.iHeartMedia.com
www.iHeartRadio.com
[#iheartradio](https://www.instagram.com/iheartradio)

February 17, 2023

VIA EMAIL

Ms. Marlene H. Dortch, Secretary
Federal Communications Commission
45 L Street NE
Washington, DC 20554

RE: IHM LICENSES, LLC (FRN No. 0014042816)
FCC Form 302-AM
KBME (AM), 790 kHz, Houston, TX; Facility ID No. 23082

Dear Ms. Dortch:

On behalf of IHM LICENSES, LLC, the licensee of the above-referenced station, enclosed is a copy of FCC Form 302-AM.

Please contact the undersigned with any communications concerning this application.

Respectfully submitted,
IHM LICENSES, LLC

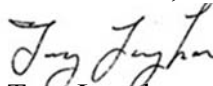
By: 
Troy Langham
VP, Technical Regulatory Affairs

cc: Public Inspection File

FOR
FCC
USE
ONLY

FCC 302-AM
APPLICATION FOR AM
BROADCAST STATION LICENSE

(Please read instructions before filling out form.)

FOR COMMISSION USE ONLY

FILE NO.

SECTION I - APPLICANT FEE INFORMATION

1. PAYOR NAME (Last, First, Middle Initial)

IHM LICENSES, LLC

MAILING ADDRESS (Line 1) (Maximum 35 characters)

7136 S YALE AVE

MAILING ADDRESS (Line 2) (Maximum 35 characters)

SUITE 501

CITY

TULSA

STATE OR COUNTRY (if foreign address)

OK

ZIP CODE

74136

TELEPHONE NUMBER (include area code)

918-664-4581

CALL LETTERS

KBME

OTHER FCC IDENTIFIER (If applicable)

23082

2. A. Is a fee submitted with this application?

Yes

No

B. If No, indicate reason for fee exemption (see 47 C.F.R. Section

Governmental Entity

Noncommercial educational licensee

Other (Please explain):

C. If Yes, provide the following information:

Enter in Column (A) the correct Fee Type Code for the service you are applying for. Fee Type Codes may be found in the "Mass Media Services Fee Filing Guide." Column (B) lists the Fee Multiple applicable for this application. Enter fee amount due in Column (C).

(A)

FEE TYPE CODE		
M	M	R

(B)

FEE MULTIPLE			
0	0	0	1

(C)

FEE DUE FOR FEE TYPE CODE IN COLUMN (A)
\$ 645.00

FOR FCC USE ONLY

To be used only when you are requesting concurrent actions which result in a requirement to list more than one Fee Type Code.

(A)

M	O	R
----------	----------	----------

(B)

0	0	0	1
----------	----------	----------	----------

(C)

\$ 1260.00

FOR FCC USE ONLY

ADD ALL AMOUNTS SHOWN IN COLUMN C, AND ENTER THE TOTAL HERE. THIS AMOUNT SHOULD EQUAL YOUR ENCLOSED REMITTANCE.

TOTAL AMOUNT REMITTED WITH THIS APPLICATION

\$ 1905.00

FOR FCC USE ONLY

SECTION II - APPLICANT INFORMATION		
1. NAME OF APPLICANT IHM LICENSES, LLC		
MAILING ADDRESS 7136 S YALE AVE, SUITE 501		
CITY TULSA	STATE OK	ZIP CODE 74136

2. This application is for:

- Commercial
 Noncommercial
 AM Directional
 AM Non-Directional

Call letters KBME	Community of License HOUSTON, TX	Construction Permit File No. BP-20220303AAS	Modification of Construction Permit File No(s).	Expiration Date of Last Construction Permit 05/31/2025
----------------------	-------------------------------------	--	---	---

3. Is the station now operating pursuant to automatic program test authority in accordance with 47 C.F.R. Section 73.1620?

Yes No

If No, explain in an Exhibit.

Exhibit No.

4. Have all the terms, conditions, and obligations set forth in the above described construction permit been fully met?

Yes No

If No, state exceptions in an Exhibit.

Exhibit No.

5. Apart from the changes already reported, has any cause or circumstance arisen since the grant of the underlying construction permit which would result in any statement or representation contained in the construction permit application to be now incorrect?

Yes No

If Yes, explain in an Exhibit.

Exhibit No.

6. Has the permittee filed its Ownership Report (FCC Form 323) or ownership certification in accordance with 47 C.F.R. Section 73.3615(b)?

Yes No

If No, explain in an Exhibit.

Does not apply

Exhibit No.

7. Has an adverse finding been made or an adverse final action been taken by any court or administrative body with respect to the applicant or parties to the application in a civil or criminal proceeding, brought under the provisions of any law relating to the following: any felony; mass media related antitrust or unfair competition; fraudulent statements to another governmental unit; or discrimination?

Yes No

If the answer is Yes, attach as an Exhibit a full disclosure of the persons and matters involved, including an identification of the court or administrative body and the proceeding (by dates and file numbers), and the disposition of the litigation. Where the requisite information has been earlier disclosed in connection with another application or as required by 47 U.S.C. Section 1.65(c), the applicant need only provide: (i) an identification of that previous submission by reference to the file number in the case of an application, the call letters of the station regarding which the application or Section 1.65 information was filed, and the date of filing; and (ii) the disposition of the previously reported matter.

Exhibit No.

8. Does the applicant, or any party to the application, have a petition on file to migrate to the expanded band (1605-1705 kHz) or a permit or license either in the existing band or expanded band that is held in combination (pursuant to the 5 year holding period allowed) with the AM facility proposed to be modified herein?

Yes No

If Yes, provide particulars as an Exhibit.

Exhibit No.

The APPLICANT hereby waives any claim to the use of any particular frequency or of the electromagnetic spectrum as against the regulatory power of the United States because use of the same, whether by license or otherwise, and requests and authorization in accordance with this application. (See Section 304 of the Communications Act of 1934, as amended).

The APPLICANT acknowledges that all the statements made in this application and attached exhibits are considered material representations and that all the exhibits are a material part hereof and are incorporated herein as set out in full in

CERTIFICATION

1. By checking Yes, the applicant certifies, that, in the case of an individual applicant, he or she is not subject to a denial of federal benefits that includes FCC benefits pursuant to Section 5301 of the Anti-Drug Abuse Act of 1988, 21 U.S.C. Section 862, or, in the case of a non-individual applicant (e.g., corporation, partnership or other unincorporated association), no party to the application is subject to a denial of federal benefits that includes FCC benefits pursuant to that section. For the definition of a "party" for these purposes, see 47 C.F.R. Section 1.2002(b).

Yes No

2. I certify that the statements in this application are true, complete, and correct to the best of my knowledge and belief, and are made in good faith.

Name Troy Langham	Signature Troy Langham <small>Digitally signed by Troy Langham DN: cn=Troy Langham, o, ou, email=TroyLangham@iheartmedia.com, c=US Date: 2023.02.17 07:22:45 -06'00'</small>	
Title VP, Technical Regulatory Affairs	Date 2/14/2023	Telephone Number 918-664-4581

WILLFUL FALSE STATEMENTS ON THIS FORM ARE PUNISHABLE BY FINE AND/OR IMPRISONMENT (U.S. CODE, TITLE 18, SECTION 1001), AND/OR REVOCATION OF ANY STATION LICENSE OR CONSTRUCTION

FCC NOTICE TO INDIVIDUALS REQUIRED BY THE PRIVACY ACT AND THE PAPERWORK REDUCTION ACT

The solicitation of personal information requested in this application is authorized by the Communications Act of 1934, as amended. The Commission will use the information provided in this form to determine whether grant of the application is in the public interest. In reaching that determination, or for law enforcement purposes, it may become necessary to refer personal information contained in this form to another government agency. In addition, all information provided in this form will be available for public inspection. If information requested on the form is not provided, the application may be returned without action having been taken upon it or its processing may be delayed while a request is made to provide the missing information. Your response is required to obtain the requested authorization.

Public reporting burden for this collection of information is estimated to average 639 hours and 53 minutes per response, including the time for reviewing instructions, searching existing data sources, gathering and maintaining the data needed, and completing and reviewing the collection of information. Comments regarding this burden estimate or any other aspect of this collection of information, including suggestions for reducing the burden, can be sent to the Federal Communications Commission, Records Management Branch, Paperwork Reduction Project (3060-0627), Washington, D. C. 20554. Do NOT send completed forms to this address.

THE FOREGOING NOTICE IS REQUIRED BY THE PRIVACY ACT OF 1974, P.L. 93-579, DECEMBER 31, 1974, 5 U.S.C. 552a(e)(3), AND THE PAPERWORK REDUCTION ACT OF 1980, P.L. 96-511, DECEMBER 11, 1980, 44 U.S.C. 3507.

SECTION III - LICENSE APPLICATION ENGINEERING DATA

Name of Applicant
IHM Licensees, LLC

PURPOSE OF AUTHORIZATION APPLIED FOR: (check one)

- Station License
 BMML- Direct Measurement of Power

1. Facilities authorized in construction permit					
Call Sign KBME	File No. of Construction Permit (if applicable) BP-20220303AAS	Frequency (kHz) 790	Hours of Operation Unlimited	Power in kilowatts	
				Night 5	Day 5
2. Station location					
State Texas			City or Town Houston		
3. Transmitter location					
State TX	County Harris		City or Town Houston	Street address (or other identification) 3000 Hansom Rd	
4. Main studio location					
State TX	County Harris		City or Town Houston	Street address (or other identification) 1233 West Loop South	
5. Remote control point location (specify only if authorized directional antenna)					
State TX	County Harris		City or Town Houston	Street address (or other identification) 1233 West Loop South	

6. Has type-approved stereo generating equipment been installed? Yes No
7. Does the sampling system meet the requirements of 47 C.F.R. Section 73.68? Yes No
- Not Applicable

Attach as an Exhibit a detailed description of the sampling system as installed.

Exhibit No. Eng Stmt

8. Operating constants:	
RF common point or antenna current (in amperes) without modulation for night system 10.39	RF common point or antenna current (in amperes) without modulation for day system 10.39
Measured antenna or common point resistance (in ohms) at operating frequency Night 50 Day 50	Measured antenna or common point reactance (in ohms) at operating frequency Night -j 4 Day -j 4

Antenna indications for directional operation						
Towers	Antenna monitor Phase reading(s) in degrees		Antenna monitor sample current ratio(s)		Antenna base currents	
	Night	Day	Night	Day	Night	Day
See Engineering Figures 3 & 4						

Manufacturer and type of antenna monitor: **Potomac Instruments, Model 1901-8**

SECTION III - Page 2

9. Description of antenna system ((f directional antenna is used, the information requested below should be given for each element of the array. Use separate sheets if necessary.)

Type Radiator Uniform cross-section, guyed, tower	Overall height in meters of radiator above base insulator, or above base, if grounded. 103.5	Overall height in meters above ground (without obstruction lighting) 104.9	Overall height in meters above ground (include obstruction lighting) 106.2	If antenna is either top loaded or sectionalized, describe fully in an Exhibit. <div style="border: 1px solid black; padding: 2px; width: fit-content;">Exhibit No. N/A</div>
--	---	---	---	--

Excitation Series Shunt

Geographic coordinates to nearest second. For directional antenna give coordinates of center of array. For single vertical radiator give tower location.

North Latitude 29 ° 54 ' 56 "	West Longitude 95 ° 27 ' 45 "
-------------------------------	-------------------------------

If not fully described above, attach as an Exhibit further details and dimensions including any other antenna mounted on tower and associated isolation circuits.

Exhibit No.
Eng Stmt

Also, if necessary for a complete description, attach as an Exhibit a sketch of the details and dimensions of ground system.

Exhibit No.
On file

10. In what respect, if any, does the apparatus constructed differ from that described in the application for construction permit or in the permit?

None

11. Give reasons for the change in antenna or common point resistance.

N/A

I certify that I represent the applicant in the capacity indicated below and that I have examined the foregoing statement of technical information and that it is true to the best of my knowledge and belief.

Name (Please Print or Type) James D. Sadler	Signature (check appropriate box below) 
Address (include ZIP Code) Carl T. Jones Corporation 7901 Yarnwood Ct Springfield, VA 22153	Date February 6, 2023
	Telephone No. (Include Area Code) (703) 569-7704

- | | |
|---|---|
| <input type="checkbox"/> Technical Director | <input type="checkbox"/> Registered Professional Engineer |
| <input type="checkbox"/> Chief Operator | <input checked="" type="checkbox"/> Technical Consultant |
| <input type="checkbox"/> Other (specify) | |



**ENGINEERING EXHIBIT
IN SUPPORT OF AN
APPLICATION FOR STATION LICENSE
STATION KBME - HOUSTON, TEXAS
790 kHz – 5 kW-D, 5 kW-N, U, DA-2
Facility ID: 23082**

Applicant: IHM Licensees, LLC

FEBRUARY, 2023

7901 Yarnwood Court
Springfield, VA 22153-2899



tel: (703) 569-7704
fax: (703) 569-6417



email: info@ctjc.com
www.ctjc.com

TABLE OF CONTENTS

SECTION III OF FCC FORM 302-AM

ENGINEERING STATEMENT OF JAMES D. SADLER

FIGURE

Tower Model Height and Radius.....	1
Measured and Modeled Impedances.....	2
Daytime Antenna Monitor Parameters and Common Point Data	3
Nighttime Antenna Monitor Parameters and Common Point Data	4
Sample Line Verification Measurements	5
Sample Device Verification Measurements	6
Reference Field Strength Measurements	7
Measured Spurious and Harmonic Emissions – Daytime Operation	8
Measured Spurious and Harmonic Emissions – Nighttime Operation	9
Phasing and Coupling System Schematic Diagram	10
Tri-Plex Filter Circuit Schematic Diagram	11

Individual Tower Model	Appendix A
Daytime Directional Array Model	Appendix B
Nighttime Directional Array Model	Appendix C
Detune Model.....	Appendix D



**ENGINEERING STATEMENT OF JAMES D. SADLER
IN SUPPORT OF AN
APPLICATION FOR STATION LICENSE
STATION KBME - HOUSTON, TEXAS
790 kHz – 5 kW-D, 5 kW-N, U, DA-2
Facility ID: 23082**

Applicant: IHM Licensees, LLC

I am a Technical Consultant, an employee in the firm of Carl T. Jones Corporation, with offices located in Springfield, Virginia. My education and experience are a matter of record with the Federal Communications Commission.

1.0 GENERAL

This office has been authorized by IHM Licensees (“IHM”), licensee of AM Radio Station KBME, to prepare this engineering statement, FCC Form 302-AM, Section III, and the associated figures and appendices in support of an Application for License to cover outstanding Construction Permit, FCC File No. BP-20220303AAS, granted May 31, 2022. The construction permit corrects the geographic coordinates for the center of the directional antenna array. KBME is licensed for operation on 790 kilohertz at a power of 5 kilowatts during daytime and nighttime hours. The station uses a four tower directional antenna during daytime hours and an eight tower directional antenna during



nighttime hours (DA-2). The four daytime towers are shared with the nighttime directional array.

IHM is the licensee of AM Stations KPRC and KXYZ, both licensed to serve Houston, Texas. Each station holds a construction permit¹ authorizing relocation of the transmission facilities to the transmitter site of KBME. Station KPRC is authorized to operate on 950 kilohertz at a daytime power of 7 kilowatts and a nighttime power of 4.3 kilowatts employing a single tower for daytime non-directional operation and 4 towers for nighttime directional operation (DA-N). Station KXYZ is authorized to operate on 1320 kHz at a daytime power of 8.4 kilowatts and a nighttime power of 2.8 kilowatts employing the same three towers for directional operation during daytime and nighttime hours (DA-2).

After completion of the installation of the new KPRC and KXYZ phasing and coupling systems and all triplexing filters required to minimize interaction between the three collocated stations, the KBME directional antenna patterns were verified using computer modeling and sample system verification techniques as described in Section 47 CFR 73.151(c) of the FCC's Rules and Regulations. The specific measurement and modeling techniques used in performing the verification of the KBME daytime and nighttime directional patterns are described in detail in this engineering statement.

Impedance measurement data, sample system verification measurement data, model derived operating parameters and reference point field strength data are tabulated in the figures attached to this engineering statement. All pertinent computer model input and output files are contained in the attached Appendices A, B, C, and D.

¹ Station KPRC construction permit, BP-20200917AAN, granted January 13, 2021, and Station KXYZ construction permit, BP-20210125AAC, granted May 4, 2021.

2.0 IMPEDANCE MEASUREMENTS, COMPUTER MODELING AND SAMPLE SYSTEM VERIFICATION

The proof of performance contained herein is based on the computer modeling and sample system verification procedures described in Section 47 CFR 73.151(c) of the FCC's Rules and Regulations. The KBME antenna array consists of eight, triangular, uniform cross-section, guyed, series fed towers. The height of each tower is 98.2 electrical degrees. The sampling system employs identical toroidal current transformers located at the output of each antenna matching network. This location corresponds to the input to the triplexing filters.

2.1 INDIVIDUAL TOWER IMPEDANCE MEASUREMENTS

Tower base impedance measurements were performed at a location immediately adjacent to the KBME sample current transformer on the tower side of the transformer. The impedance measurements were performed by Mr. Nicolas Blomstrand, Corporate RF Engineer for the licensee, and the undersigned, using a Keysight, Model P5020A vector network analyzer; an ENI, Model 325LA, power amplifier; and a Tunwall Radio directional coupler. The impedance of each tower was measured with the other towers open-circuited at the same ATU output J-Plug location that was used to perform the impedance measurement. The measured impedances are tabulated in Figure 2.

2.2 INDIVIDUAL TOWER COMPUTER MODELS

A Method of Moments ("MoM") computer model was developed to model each element in the array using Expert MiniNEC Broadcast Professional (Version 23.0). A

wire model consisting of 24 segments was developed for each of the eight towers. To replicate the individual measured base impedances to within FCC specified tolerances, each tower's physical height was adjusted in the MiniNEC model and series inductances, shunt capacitances and measured series capacitances were employed in a separate circuit model.² The actual equivalent physical radius of each tower was used in all computer models contained in this application for all but one tower. Details of the modeled individual tower adjusted radius and tower heights are contained in Figure 1.

The values of the shunt capacitances, lumped series inductances and measured series capacitances used in the circuit model are contained in the table of Figure 2. A comparison of the measured individual tower impedances, the modeled individual tower impedances, and the adjusted modeled (circuit model) individual tower impedances is also contained in the table of Figure 2. The percentage difference between the adjusted modeled tower radius and height and the actual physical tower radius and height and the magnitude of the lumped series inductances and shunt capacitances that were used in the circuit models are all within the tolerances set forth in the Rules.

As demonstrated by the data contained in Figure 2, the adjusted modeled individual tower resistance and reactance for each tower is well within ± 2 ohms and ± 4 percent tolerance of the corresponding measured individual tower resistance and reactance. The text files containing all pertinent input and output data associated with the individual tower models are contained in Appendix A.

² A variable vacuum capacitor was installed in series with the input to each tower that was in common with all three station's transmission paths. After final adjustment, the value of each series capacitor was measured at all three frequencies and the measured capacitance values at 790 kHz were used in the KBME separate circuit model.

2.3 DIRECTIONAL ANTENNA COMPUTER MODEL AND ANTENNA MONITOR PARAMETERS

The KBME theoretical daytime and nighttime directional field parameters and the licensed tower spacings and orientations were used in combination with the adjusted individual tower models to produce the daytime and nighttime directional antenna computer models. From the daytime and nighttime directional computer models, tower currents were derived that, when numerically integrated and normalized to the appropriate reference tower, are essentially identical to the theoretical relative field parameters for the KBME daytime and nighttime directional antenna patterns.

The new daytime and nighttime directional array operating parameters were determined from the modeled base currents and are tabulated in Figures 3 and 4. The text files containing all pertinent input and output data associated with the daytime and nighttime directional antenna computer models are contained in Appendix B and C. Note that in Appendix B the unused towers (#3, #4, #5, and #6) are included in the model. The unused towers are detuned at their base using the detuning impedance determined by modeling for the adjusted tower's height. Details of the detune model are contained in Appendix D.

2.4 SAMPLE SYSTEM DESCRIPTION AND VERIFICATION MEASUREMENTS

The KBME antenna sampling system is comprised of: 1) Delta Electronics, Model TCT-3, toroidal current transformers mounted in an identical manner in the output branch of each tower's impedance matching network; 2) equal lengths of 3/8-inch, foam dielectric, coaxial cable; and 3) a Potomac Instruments, Model 1901-8, antenna monitor. Each sample line between the ATU building and the transmitter building, including

excess lengths, is buried such that each cable is subjected to the same environmental conditions.

The sample lines were verified to be equal in length by measuring the open-circuit series resonate frequency closest to the carrier frequency. The characteristic impedance was verified by measuring the impedance at frequencies corresponding to odd multiples of 1/8 wavelength immediately above and below the open circuit series resonant frequency closest to the carrier frequency, while the line was open-circuited at the sample element end of the line. The characteristic impedance was calculated by the following formula:

$$Z = \sqrt{\sqrt{R_1^2 + X_1^2} \times \sqrt{R_2^2 + X_2^2}}$$

where:

Z = Characteristic impedance and

R₁ + j X₁ and R₂ + j X₂ are the measured impedances

at ± 45 degrees offset frequencies.

A tabulation of the measured sample line lengths and the characteristic impedance of each line is contained in Figure 5. All sample line verification measurements were performed by Mr. Randy Mullinax and Mr. Nicolas Blomstrand, using a Keysight, Model P5020A vector network analyzer; an ENI, Model 325LA, power amplifier; and a Tunwall Radio directional coupler. Mr. Mullinax is also a Corporate RF Engineer for the licensee. As demonstrated by the measured values in Figure 5, the measured sample line lengths are within 1 electrical degree with respect to each other

and the measured characteristic impedances are within 2 ohms of each other, as required by Section 47 CFR 73.151(c)(2)(I) of the FCC Rules and Regulations.

An impedance measurement was performed at the input to each sample line, at the antenna monitor end of the line, with the toroidal current transformer connected. The measurement was performed at the KBME operating frequency of 790 kilohertz. The measured sample line impedances with the current transformers connected are tabulated in Figure 5 under the heading "Reference Impedance Sample Transformer Connected."

The performance of the toroidal current transformers was verified by driving a common reference current through the eight KBME transformers and comparing the relative outputs as observed on the network analyzer. The test confirmed that the performance of all eight of the KBME current transformers is well within the manufacturer's stated accuracy. A tabulation of the toroidal current transformer measurement data and the serial number of each toroidal current transformer is contained in Figure 6.

The antenna monitor that is employed by KBME is a Potomac Instruments, Model 1901-8. The performance of the antenna monitor was verified by Mr. Randy Mullinax and found to be well within the manufacturers stated accuracy.

3.0 COMMON POINT IMPEDANCE AND COMMON POINT CURRENT

The networks associated with the daytime and nighttime directional antenna system were adjusted for proper impedance transformation and each common point impedance matching network was set for $Z = 50 -j 4$ Ohms (uncorrected inline bridge

reading). The transmitter output power level was adjusted for a daytime and nighttime common point current of 10.39 amperes, corresponding to daytime and nighttime input power of 5,400 Watts.

4.0 REFERENCE FIELD STRENGTH MEASUREMENTS

Reference field strength measurements were performed on the KBME daytime directional antenna pattern on the 166.5° radial bearing, corresponding to the major lobe of the daytime pattern. In addition, reference field strength measurements were performed on the 232°, and 352.5° radial bearings, corresponding to the daytime directional pattern minima. Reference field strength measurements were performed on the KBME nighttime directional antenna pattern on the 151.5° radial bearing, corresponding to the major lobe of the nighttime pattern. In addition, reference field strength measurements were performed on the 47°, 116.5°, 197.5°, 233.5°, and 302.5° radial bearings, corresponding to the nighttime directional pattern minima. Three reference field strength measurements were performed on each of the selected radial bearings.

The measurements were performed by Mr. Randy Mullinax and Mr. Nicolas Blomstrand. A single Potomac Instruments, Model PI-4100, Serial Number 133, last calibrated June, 2021, was used to perform the measurements.

The measured field strength value for each established reference point location is tabulated in Figure 7, Sheets 1 through 5. The tabulations contained in Figure 7 also include for each reference location; GPS coordinates (NAD83), distance from the KBME array center, and a description of measurement location.

5.0 SPURIOUS EMISSION MEASUREMENTS

IHM has designed, purchased, installed and adjusted filtering and detuning equipment sufficient to prevent interaction and the generation of spurious emissions. The schematic diagram of Figure 10 shows the KBME phasing and coupling system. The schematic diagrams of Figure 11, Sheets 1 through 8 show the tri-plexing filters and detuning circuits that have been installed at the base of each tower for this purpose.

Measurements of spurious and harmonic emissions radiated by the combined operations of KBME, KPRC and KXYZ were performed by the Mr. Randy Mullinax and Mr. Nicolas Blomstrand. The measurement data confirms that all spurious and harmonic emissions generated by the common usage of the transmitter site and antennas are below the emissions limits specified in Section 73.44(b) of the Commission's Rules and Regulations. Also included in the measurements were intermodulation products that included nearby stations operating on 1070 kHz and 610 kHz. The spurious, harmonic and intermodulation product emission measurement data is tabulated in Figures 8 and 9.

6.0 OTHER ANTENNAS MOUNTED ON THE TOWER

An STL antenna is mounted on tower #5(NE). A Kintronic Laboratories isocoupler is mounted across the base insulator of tower #5.

7.0 SUMMARY

It is submitted that the KBME daytime and nighttime directional antenna systems have been properly adjusted to comply with the technical specifications contained in

Construction Permit, FCC File No. BP-20220303AAS. The daytime and nighttime directional pattern performance has been verified using computer modeling and sample system verification procedures in accordance with Section 47 CFR 73.151(c) of the Commission's Rules and Regulations. It is believed that the daytime and nighttime directional antenna patterns, as adjusted, fully comply with the terms of the station's FCC Authorization and all applicable FCC Rules and Regulations. It is requested that a license be issued to IHM reflecting the new MoM model derived operating parameters as contained herein and in Section III of FCC Form 302-AM.

This engineering statement, FCC Form 302-AM, Section III, and the attached figures and appendices were prepared by the undersigned or under the direct supervision of the undersigned and are believed to be true and correct.

Dated: February 6, 2023

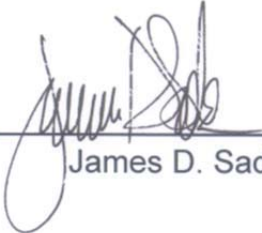

James D. Sadler

Figure 1

TOWER MODEL HEIGHT AND RADIUS

STATION KBME - HOUSTON, TEXAS

790 kHz - 5 kW-D, 5 kW-N, U, DA-2

FEBRUARY, 2023

Tower	Physical Height (meters)	Modeled Height (meters)	Percent of Physical Height	Modeled Radius (meters)	Percent of Equivalent Radius
1	103.5	107.6	103.9	0.2911	100.0
2	103.5	110.2	106.5	0.2911	100.0
3	103.5	111.2	107.4	0.2911	100.0
4	103.5	107.4	103.7	0.2911	100.0
5	103.5	108.8	105.1	0.2358	81.0
6	103.5	111.3	107.5	0.2911	100.0
7	103.5	111.8	108.0	0.2911	100.0
8	103.5	109.2	105.5	0.2911	100.0

MEASURED AND MODELED IMPEDANCES

STATION KBME - HOUSTON, TEXAS
790 kHz - 5 kW-D, 5 kW-N, U, DA-2
FEBRUARY, 2023

Tower	Measured Tower Base Impedance ¹	Modeled Tower Base Impedance	Shunt Capacitance (pF)	Modeled plus Shunt Reactance	Measured Series Capacitance (pF)	Lumped Series Inductance (uH)	Total Adjusted Tower Base Impedance
1	68.82 +j 7.33	67.91 +j 94.45	15.0	68.88 +j 94.77	1730	5.9	68.88 +j 7.36
2	72.76 -j 170.0	71.60 +j 111.46	15.0	72.80 +j 112.00	677.8	3.1	72.80 -j 170.0
3	74.82 -j 17.64	73.49 +j 116.73	15.0	74.78 +j 117.34	1330	3.3	74.78 -j 17.65
4	65.66 -j 63.19	64.79 +j 91.43	15.0	65.68 +j 91.74	1090	6.0	65.68 -j 63.21
5	64.81 +j 28.51	67.58 +j 102.95	15.0	68.63 +j 103.40	1590	10.0	68.63 +j 26.33
6	75.00 -j 46.16	73.64 +j 117.33	15.0	74.94 +j 117.95	1040	6.0	74.94 -j 46.23
7	77.21 -j 10.15	75.72 +j 121.29	15.0	77.10 +j 121.96	1280	5.1	77.10 -j 10.12
8	73.19 -j 93.22	72.15 +j 104.57	15.0	73.29 +j 104.99	938.4	3.3	73.29 -j 93.31

¹ Measured at output of matching network with other towers open-circuited.

**ANTENNA MONITOR PARAMETERS
AND COMMON POINT DATA**

STATION KBME - HOUSTON, TEXAS

790 kHz - 5 kW-D, 5 kW-N, U, DA-2

FEBRUARY, 2023

DAYTIME		
Tower	Modeled Parameters	
	Ratio	Phase (deg)
1(NW) - ASR#1058670	1.000	0.0
2(NWC) - ASR#1058671	0.147	-107.4
7(SEC) - ASR#1058676	0.535	-89.9
8(SE) - ASR#1058677	0.065	-156.0

Common Point Impedance = 50 -j 4 ohms
Common Point Current = 10.39 amperes
Antenna Input Power = 5,400 Watts

**NIGHTTIME ANTENNA MONITOR PARAMETERS
AND COMMON POINT DATA**

STATION KBME - HOUSTON, TEXAS

790 kHz - 5 kW-D, 5 kW-N, U, DA-2

FEBRUARY, 2023

Tower	Modeled Parameters	
	Ratio	Phase (deg)
1(NW) - ASR#1058670	1.290	8.2
2(NWC) - ASR#1058671	1.188	-156.6
3(SWC) - ASR#1058672	1.477	42.0
4(SW) - ASR#1058673	0.588	-66.9
5(NE) - ASR#1058674	1.000	0.0
6(NEC) - ASR#1058675	0.867	-165.5
7(SEC) - ASR#1058676	1.130	29.7
8(SE) - ASR#1058677	0.422	-78.1
<p align="center">Common Point Impedance = 50 -j 4 ohms Common Point Current = 10.39 amperes Antenna Input Power = 5,400 Watts</p>		

SAMPLE LINE VERIFICATION MEASUREMENTS

STATION KBME - HOUSTON, TEXAS
790 kHz - 5 kW-D, 5 kW-N, U, DA-2
FEBRUARY, 2023

Tower	Open Circuit Series Resonant Frequency ¹ (kHz)	Open Circuit Measured Line Length ² (degrees)	Resonant Frequency -45 degree Offset Frequency (kHz)	Resonant Frequency -45 degree Offset Impedance (Ohms)	Resonant Frequency +45 degree Offset Frequency (kHz)	Resonant Frequency +45 degree Offset Impedance (Ohms)	Calculated Characteristic Impedance (Ohms)	Reference Impedance Sample Toroid Connected ² (Ohms)
1	895.85	555.56	831.86	14.88 -j 47.14	959.84	16.89 +j 46.03	49.23	50.46 +j 2.30
2	895.86	555.56	831.87	14.73 -j 46.74	959.85	16.93 +j 45.96	48.99	49.33 +j 1.54
3	895.50	555.78	831.54	14.44 -j 45.34	959.46	16.88 +j 46.01	48.29	48.59 -j 0.16
4	895.90	555.53	831.91	14.80 -j 47.54	959.89	17.71 +j 47.53	50.25	50.53 +j 1.67
5	895.75	555.62	831.77	14.94 -j 47.04	959.73	17.24 +j 46.36	49.41	51.83 +j 0.23
6	895.74	555.63	831.76	14.78 -j 47.56	959.72	17.53 +j 47.38	50.16	50.26 +j 1.48
7	895.87	555.55	831.88	15.21 -j 48.00	959.86	16.91 +j 46.50	49.91	49.58 +j 2.12
8	895.99	555.47	831.99	14.66 -j 47.10	959.99	17.59 +j 47.19	49.84	50.11 +j 2.28

¹ At this frequency, the sample line electrical length is equal to 630°.

² At carrier frequency (790 kHz)

SAMPLE DEVICE VERIFICATION MEASUREMENTS

STATION KBME - HOUSTON, TEXAS

790 kHz - 5 kW-D, 5 kW-N, U, DA-2

FEBRUARY, 2023

Reference Sample Toroid Number	Measured Sample Toroid Number	Measured	
		Field Ratio	Phase (degrees)
7	1	1.000	0.34
7	2	1.000	-0.04
7	3	0.999	0.11
7	4	0.999	0.16
7	5	1.000	0.09
7	6	1.000	-0.28
7	8	0.999	0.58

Sample Toroid Number	Type	Serial Number
1	Delta Electronics, TCT-3	18267
2	Delta Electronics, TCT-3	96
3	Delta Electronics, TCT-3	17942
4	Delta Electronics, TCT-3	17694
5	Delta Electronics, TCT-3	17943
6	Delta Electronics, TCT-3	17145
7	Delta Electronics, TCT-3	17659
8	Delta Electronics, TCT-3	18226

REFERENCE FIELD STRENGTH MEASUREMENTS

STATION KBME - HOUSTON, TEXAS

790 kHz - 5 kW-D, 5 kW-N, U, DA-2

FEBRUARY, 2023

47 Degree Radial

Point Number	Distance (km)	Daytime Field (mV/m)	Nighttime Field (mV/m)	Geographic Coordinates (NAD83)		Description
				Latitude	Longitude	
1	4.08	---	17.5	29° 56' 26.4"	95° 25' 55.4"	Point is located on Grand Plaza Drive, at the end of divided road.
2	5.78	---	16	29° 57' 03.7"	95° 25' 08.5"	Point is located at the fire hydrant on the south side, opposite #13 Glenborough Drive.
3	9.14	---	6.55	29° 58' 18.2"	95° 23' 37.1"	Point is located at #1018 Carolina Wren Circle.

116.5 Degree Radial

Point Number	Distance (km)	Daytime Field (mV/m)	Nighttime Field (mV/m)	Geographic Coordinates (NAD83)		Description
				Latitude	Longitude	
1	4.55	---	83.6	29° 53' 51.0"	95° 25' 14.6"	Point is located at #1118 Twin Falls Road.
2	5.77	---	72.8	29° 53' 33.4"	95° 24' 34.3"	Point is located at #614 Rainey River Drive.
3	8.09	---	43.0	29° 52' 56.6"	95° 23' 16.6"	Point is located on the south edge of road at #191 Mitchell Road.

REFERENCE FIELD STRENGTH MEASUREMENTS

STATION KBME - HOUSTON, TEXAS

790 kHz - 5 kW-D, 5 kW-N, U, DA-2

FEBRUARY, 2023

151.5 Degree Radial

Point Number	Distance (km)	Daytime Field (mV/m)	Nighttime Field (mV/m)	Geographic Coordinates (NAD83)		Description
				Latitude	Longitude	
1	3.81	---	425	29° 53' 08.5"	95° 26' 38.8"	Point is located at the end of Logger Pines Trail.
2	8.94	---	168	29° 50' 42.5"	95° 25' 07.5"	Point is located on the northeast corner of the junction of Dunsmere Street and Marcella Street.
3	12.60	---	115	29° 48' 58.0"	95° 24' 02.0"	Point is located at the "Road Humps" sign, #220 W 32nd Street.

166.5 Degree Radial

Point Number	Distance (km)	Daytime Field (mV/m)	Nighttime Field (mV/m)	Geographic Coordinates (NAD83)		Description
				Latitude	Longitude	
1	3.23	292	---	29° 53' 14.8"	95° 27' 18.8"	Point is located at #2914 McCrarey Drive.
2	4.26	224	---	29° 52' 42.8"	95° 27' 09.4"	Point is located at #2905 Rigel Road.
3	6.47	146	---	29° 51' 32.9"	95° 26' 51.0"	Point is located at #2435 Cliffdale Street.

REFERENCE FIELD STRENGTH MEASUREMENTS

STATION KBME - HOUSTON, TEXAS

790 kHz - 5 kW-D, 5 kW-N, U, DA-2

FEBRUARY, 2023

197.5 Degree Radial

Point Number	Distance (km)	Daytime Field (mV/m)	Nighttime Field (mV/m)	Geographic Coordinates (NAD83)		Description
				Latitude	Longitude	
1	3.26	---	114	29° 53' 16.1"	95° 28' 23.2"	Point is located at #8297 Enchanted Forest Drive.
2	4.86	---	80	29° 52' 26.8"	95° 28' 41.1"	Point is located at #5922 Green Terrace Lane.
3	10.20	---	32.2	29° 49' 41.0"	95° 29' 41.3"	Point is located at #6754 Limestone Street.

232 Degree Radial

Point Number	Distance (km)	Daytime Field (mV/m)	Nighttime Field (mV/m)	Geographic Coordinates (NAD83)		Description
				Latitude	Longitude	
1	3.43	75.8	---	29° 53' 48.6"	95° 29' 27.7"	Point is located next to the fire hydrant at #6806 Bayou Crest Drive.
2	4.68	48.0	---	29° 53' 23.3"	95° 30' 04.1"	Point is located at #7314 Log View Drive.
3	6.41	38.4	---	29° 52' 49.2"	95° 30' 55.5"	Point is located at #7410 Woodoak Drive.

REFERENCE FIELD STRENGTH MEASUREMENTS

STATION KBME - HOUSTON, TEXAS

790 kHz - 5 kW-D, 5 kW-N, U, DA-2

FEBRUARY, 2023

233.5 Degree Radial

Point Number	Distance (km)	Daytime Field (mV/m)	Nighttime Field (mV/m)	Geographic Coordinates (NAD83)		Description
				Latitude	Longitude	
1	3.55	---	37.30	29° 53' 48.4"	95° 29' 33.1"	Point is located at #7003 Bayou Crest Drive.
2	4.91	---	18.30	29° 53' 22.5"	95° 30' 14.5"	Point is located at #10234 Hannon Drive.
3	6.10	---	15.10	29° 52' 59.7"	95° 30' 49.9"	Point is located at the junction of Split Oak Drive and Flair Oak Drive at the stop sign.

302.5 Degree Radial

Point Number	Distance (km)	Daytime Field (mV/m)	Nighttime Field (mV/m)	Geographic Coordinates (NAD83)		Description
				Latitude	Longitude	
1	3.24	---	61.1	29° 55' 53.1"	95° 29' 28.7"	Point is located at #7027 Sandswept Lane.
2	4.29	---	39.4	29° 56' 11.0"	95° 30' 01.7"	Point is located at #10938 Loch Bend Court.
3	12.10	---	19.1	29° 58' 26.6"	95° 34' 08.2"	Point is located at #13263 Mansfield Point Lane.

REFERENCE FIELD STRENGTH MEASUREMENTS

STATION KBME - HOUSTON, TEXAS

790 kHz - 5 kW-D, 5 kW-N, U, DA-2

FEBRUARY, 2023

352.5 Degree Radial

Point Number	Distance (km)	Daytime Field (mV/m)	Nighttime Field (mV/m)	Geographic Coordinates (NAD83)		Description
				Latitude	Longitude	
1	4.37	41.0	---	29° 57' 16.6"	95° 28' 08.5"	Point is located at junction of Copper Valley Court and Ironstone Court.
2	5.42	39.6	---	29° 57' 50.4"	95° 28' 13.0"	Point is located at #2678 Grand Canyon Drive.
3	7.39	28.0	---	29° 58' 53.5"	95° 28' 32.0"	Point is located at #13808 Sableglen Street.

**MEASURED SPURIOUS AND HARMONIC EMISSIONS
DAYTIME OPERATION**

STATION KBME - HOUSTON, TEXAS
790 kHz - 5 kW-D, 5 kW-N, U, DA-2
FEBRUARY, 2023

Measured Attenuation

<u>Emission</u>	<u>Frequency</u> (kHz)	<u>Field</u> <u>Strength</u> (mV/m)	<u>Reference</u> <u>Carrier</u>	<u>Below</u> <u>Carrier</u> (dBc)	<u>FCC</u> <u>Limit</u> (dBc)
F1	790	1050	---	---	---
F2	950	804	---	---	---
F3	1320	1500	---	---	---
F4	1070	210	---	---	---
F5	610	42.5	---	---	---
2F2-F3	580	0.022	-91.3	F2	-80.0
2F1-F2	630	0.109	(Note 1)	F1	-80.0
2F2-F1	1110	1.35	(Note 1)	F2	-80.0
F1-F2+F3	1160	0.024	-90.5	F2	-80.0
F1+F5	1400	0.431	(Note 1)	F1	-80.0
-F1+F2+F3	1480	2.17	(Note 1)	F2	-80.0
F2+F5	1560	0.953	(Note 1)	F2	-80.0
2F1	1580	0.066	(Note 2)	F1	-80.0
2F3-F2	1690	0.018	-98.4	F3	-80.0
F1+F2	1740	0.035	-89.5	F2	-80.0
2F3-F1	1850	0.025	-95.6	F3	-80.0
F1+F4	1860	0.029	-91.2	F1	-80.0
2F2	1900	0.019	-92.5	F2	-80.0
F3+F5	1930	0.011	-102.7	F3	-80.0
F2+F4	2020	0.013	-95.8	F2	-80.0
F1+F3	2110	0.052	-86.1	F1	-80.0
F5+2F1	2190	0.011	-99.6	F1	-80.0
F2+F3	2270	0.075	-80.6	F2	-80.0
F1+F2+F5	2350	0.01	-98.1	F2	-80.0
3F1	2370	0.025	-92.5	F1	-80.0
F3+F4	2390	0.025	-95.6	F3	-80.0
F5+2F2	2510	0.011	-97.3	F2	-80.0
F2+2F1	2530	0.032	-90.3	F1	-80.0
2F3	2640	0.095	-84.0	F3	-80.0
F4+2F1	2650	0.011	-99.6	F1	-80.0

Measured Attenuation

<u>Emission</u>	<u>Frequency</u> (kHz)	<u>Field</u> <u>Strength</u> (mV/m)	<u>Reference</u> <u>Carrier</u>	<u>Below</u> <u>Carrier</u> (dBc)	<u>FCC</u> <u>Limit</u> (dBc)
F1+2F2	2690	0.018	-93.0	F2	-80.0
F1+F3+F5	2720	0.01	-100.4	F1	-80.0
F1+F2+F4	2810	0.01	-98.1	F2	-80.0
3F2	2850	0.016	-94.0	F2	-80.0
F2+F3+F5	2880	0.01	-98.1	F2	-80.0
F3+2F1	2900	0.027	-91.8	F1	-80.0
F4+2F2	2970	0.01	-98.1	F2	-80.0
F1+F2+F3	3060	0.03	-88.6	F2	-80.0
F1+F3+F4	3180	0.011	-99.6	F1	-80.0
F3+2F2	3220	0.033	-87.7	F2	-80.0
F5+2F3	3250	0.058	-88.3	F3	-80.0
F2+F3+F4	3340	0.01	-98.1	F2	-80.0
F1+2F3	3430	0.043	-90.9	F3	-80.0
F2+2F3	3590	0.072	-86.4	F3	-80.0
F4+2F3	3710	0.013	-101.2	F3	-80.0
3F3	3960	0.084	-85.0	F3	-80.0

Note 1 - Signal from another station, no audio from reference station(s) observed

Note 2 - Splatter from strong local station on adjacent frequency, no audio from reference station(s) observed

**MEASURED SPURIOUS AND HARMONIC EMISSIONS
NIGHTTIME OPERATION**

STATION KBME - HOUSTON, TEXAS
790 kHz - 5 kW-D, 5 kW-N, U, DA-2
FEBRUARY, 2023

Measured Attenuation

<u>Emission</u>	<u>Frequency</u> (kHz)	<u>Field</u> <u>Strength</u> (mV/m)	<u>Reference</u> <u>Carrier</u>	<u>Below</u> <u>Carrier</u> (dBc)	<u>FCC</u> <u>Limit</u> (dBc)
F1	790	1860	---	---	---
F2	950	920	---	---	---
F3	1320	870	---	---	---
F4	1070	162	---	---	---
F5	610	10.4	---	---	---
2F2-F3	580	0.023	-92.0	F2	-79.3
2F1-F2	630	0.109	(Note 1)	F1	-80.0
2F2-F1	1110	1.22	(Note 1)	F2	-79.3
F1-F2+F3	1160	0.025	-91.3	F2	-79.3
F1+F5	1400	0.39	(Note 1)	F1	-80.0
-F1+F2+F3	1480	2.06	(Note 1)	F2	-79.3
F2+F5	1560	0.881	(Note 1)	F2	-79.3
2F1	1580	0.629	(Note 2)	F1	-80.0
2F3-F2	1690	0.017	-94.2	F3	-77.5
F1+F2	1740	0.036	-88.1	F2	-79.3
2F3-F1	1850	0.022	-91.9	F3	-77.5
F1+F4	1860	0.019	-99.8	F1	-80.0
2F2	1900	0.016	-95.2	F2	-79.3
F3+F5	1930	0.011	-98.0	F3	-77.5
F2+F4	2020	0.014	-81.3	F2	-79.3
F1+F3	2110	0.078	-87.5	F1	-80.0
F5+2F1	2190	0.011	-104.6	F1	-80.0
F2+F3	2270	0.062	-83.4	F2	-79.3
F1+F2+F5	2350	0.01	-99.3	F2	-79.3
3F1	2370	0.089	-86.4	F1	-80.0
F3+F4	2390	0.023	-91.6	F3	-77.5
F5+2F2	2510	0.011	-98.4	F2	-79.3
F2+2F1	2530	0.065	-89.1	F1	-80.0
2F3	2640	0.08	-80.7	F3	-77.5
F4+2F1	2650	0.017	-100.8	F1	-80.0

Measured Attenuation

<u>Emission</u>	<u>Frequency</u> (kHz)	<u>Field</u> <u>Strength</u> (mV/m)	<u>Reference</u> <u>Carrier</u>	<u>Below</u> <u>Carrier</u> (dBc)	<u>FCC</u> <u>Limit</u> (dBc)
F1+2F2	2690	0.035	-88.4	F2	-79.3
F1+F3+F5	2720	0.011	-104.6	F1	-80.0
F1+F2+F4	2810	0.014	-81.3	F2	-79.3
3F2	2850	0.015	-95.8	F2	-79.3
F2+F3+F5	2880	0.011	-98.4	F2	-79.3
F3+2F1	2900	0.046	-92.1	F1	-80.0
F4+2F2	2970	0.01	-99.3	F2	-79.3
F1+F2+F3	3060	0.043	-86.6	F2	-79.3
F1+F3+F4	3180	0.019	-99.8	F1	-80.0
F3+2F2	3220	0.029	-90.0	F2	-79.3
F5+2F3	3250	0.059	-83.4	F3	-77.5
F2+F3+F4	3340	0.013	-81.9	F2	-79.3
F1+2F3	3430	0.067	-82.3	F3	-77.5
F2+2F3	3590	0.036	-87.7	F3	-77.5
F4+2F3	3710	0.038	-87.2	F3	-77.5
3F3	3960	0.022	-91.9	F3	-77.5

Note 1 - Signal from another station, no audio from reference station(s) observed

Note 2 - Splatter from strong local station on adjacent frequency, no audio from reference station(s) observed

Figure 10

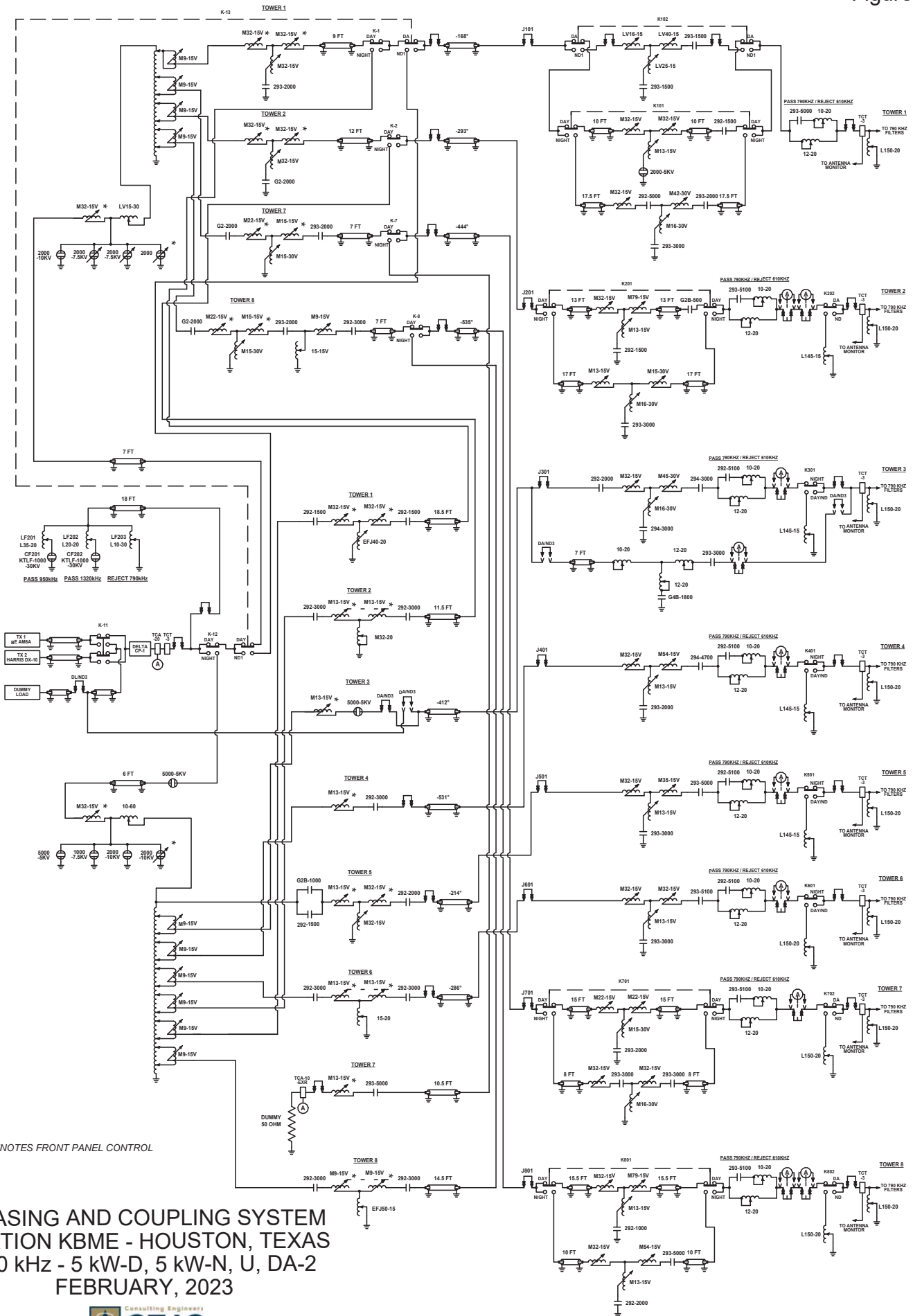

* DENOTES FRONT PANEL CONTROL

PHASING AND COUPLING SYSTEM
 STATION KBME - HOUSTON, TEXAS
 790 kHz - 5 kW-D, 5 kW-N, U, DA-2
 FEBRUARY, 2023

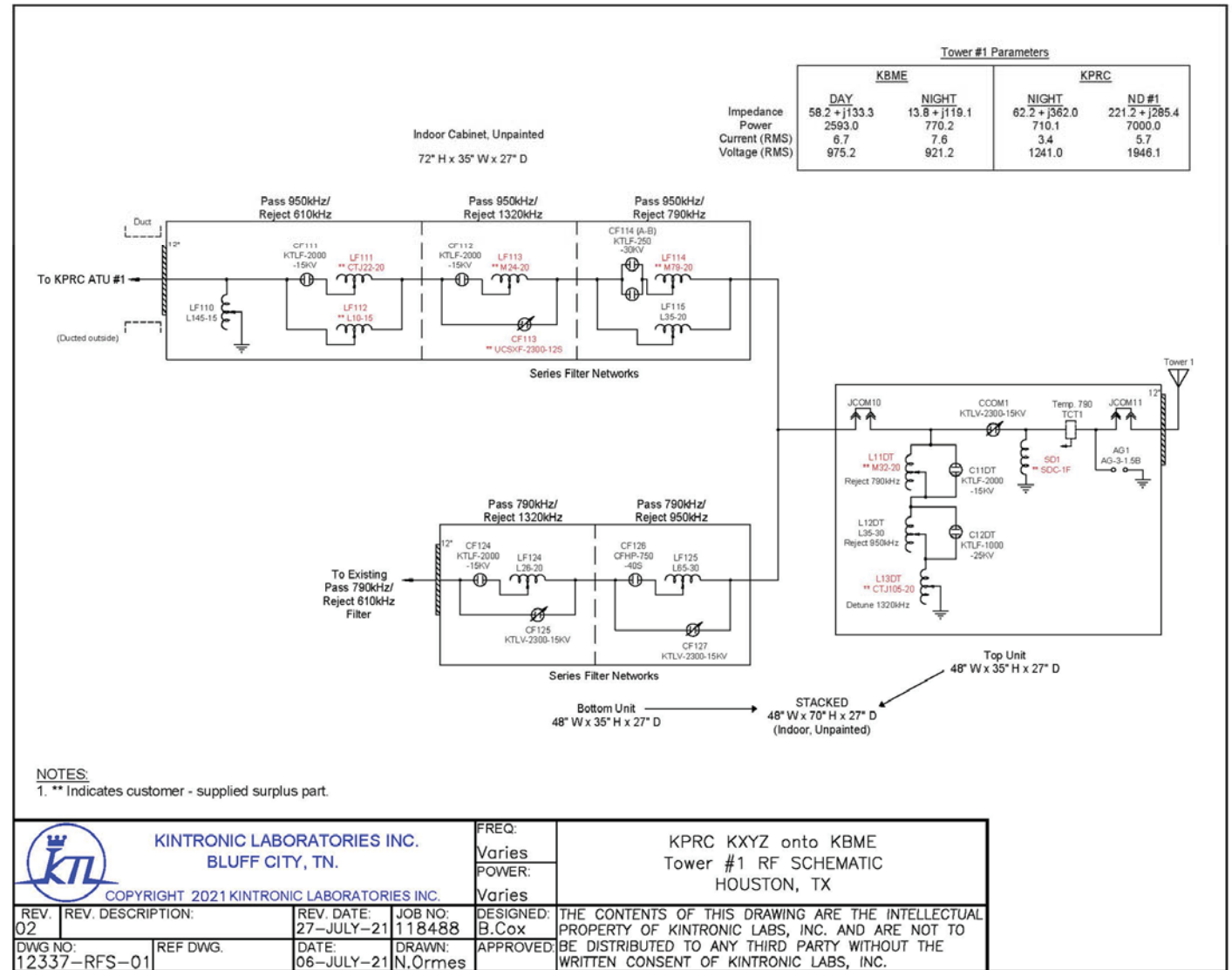

	KINTRONIC LABORATORIES INC. BLUFF CITY, TN. COPYRIGHT 2021 KINTRONIC LABORATORIES INC.		FREQ:	KPRC KXYZ onto KBME Tower #1 RF SCHEMATIC HOUSTON, TX
			Varies	
REV. 02	REV. DESCRIPTION:	REV. DATE: 27-JULY-21	JOB NO: 118488	DESIGNED: B.Cox
DWG NO: 12337-RFS-01	REF DWG.	DATE: 06-JULY-21	DRAWN: N.Ormes	APPROVED:

THE CONTENTS OF THIS DRAWING ARE THE INTELLECTUAL PROPERTY OF KINTRONIC LABS, INC. AND ARE NOT TO BE DISTRIBUTED TO ANY THIRD PARTY WITHOUT THE WRITTEN CONSENT OF KINTRONIC LABS, INC.

Figure 11
Sheet 1 of 8

Tower #2 Parameters

	KBME		KPRC	
	DAY	NIGHT	DAY	NIGHT
Impedance	261.6 + j242.1	15.3 + j183.3	212.3 + j276.5	252.3 + j219.9
Power	302.2	881.0	7000.0	3438.4
Current (RMS)	1.1	7.6	5.7	3.7
Voltage (RMS)	384.6	1407.3	2001.8	1235.5

Indoor Cabinet, Unpainted
72" H x 35" W x 27" D

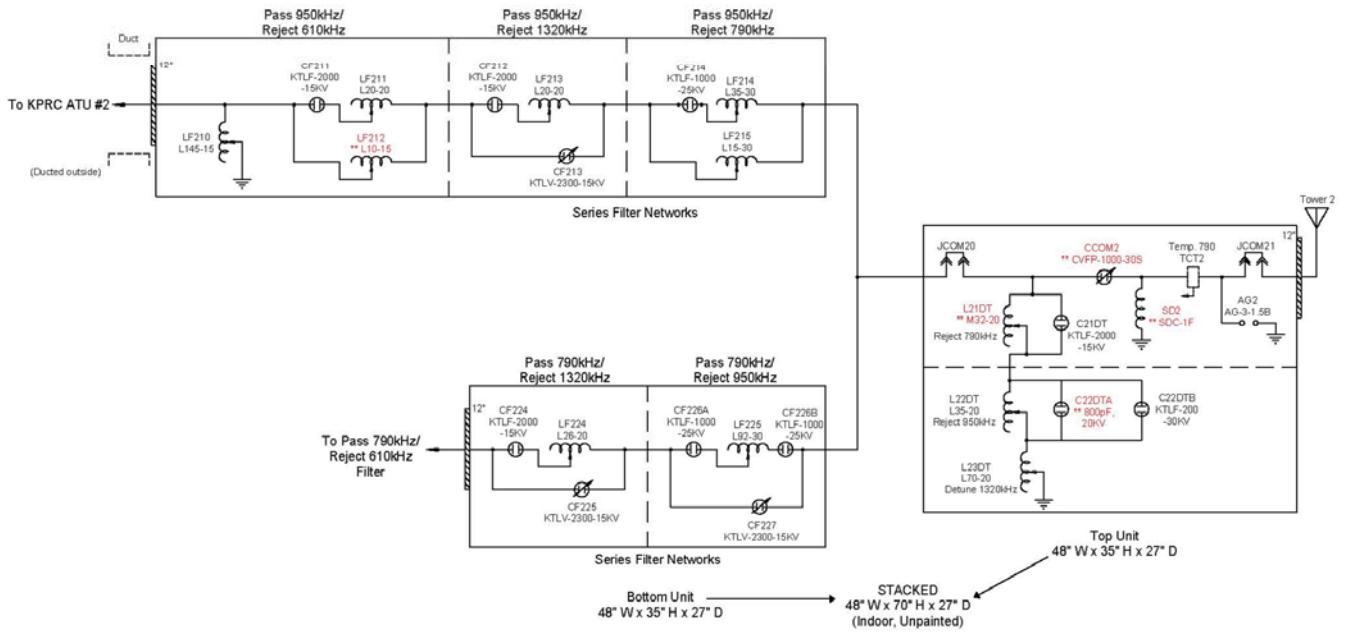

NOTES:

- 1. ** Indicates customer - supplied surplus part.

 <p>KINTRONIC LABORATORIES INC. BLUFF CITY, TN. COPYRIGHT 2021 KINTRONIC LABORATORIES INC.</p>	FREQ:	KPRC KXYZ onto KBME Tower #2 RF SCHEMATIC HOUSTON, TX			
	Varies				
	POWER:				
	Varies				
REV. 02	REV. DESCRIPTION:	REV. DATE: 27-JULY-21	JOB NO: 118488	DESIGNED: B.Cox	THE CONTENTS OF THIS DRAWING ARE THE INTELLECTUAL PROPERTY OF KINTRONIC LABS, INC. AND ARE NOT TO BE DISTRIBUTED TO ANY THIRD PARTY WITHOUT THE WRITTEN CONSENT OF KINTRONIC LABS, INC.
DWG NO: 12337-RFS-02	REF DWG.	DATE: 06-JULY-21	DRAWN: N.Ormes	APPROVED:	

Tower #3 Parameters

KBME	
NIGHT	
Impedance	8.26 + j140.4
Power	811.1
Current (RMS)	9.5
Voltage (RMS)	1336.3

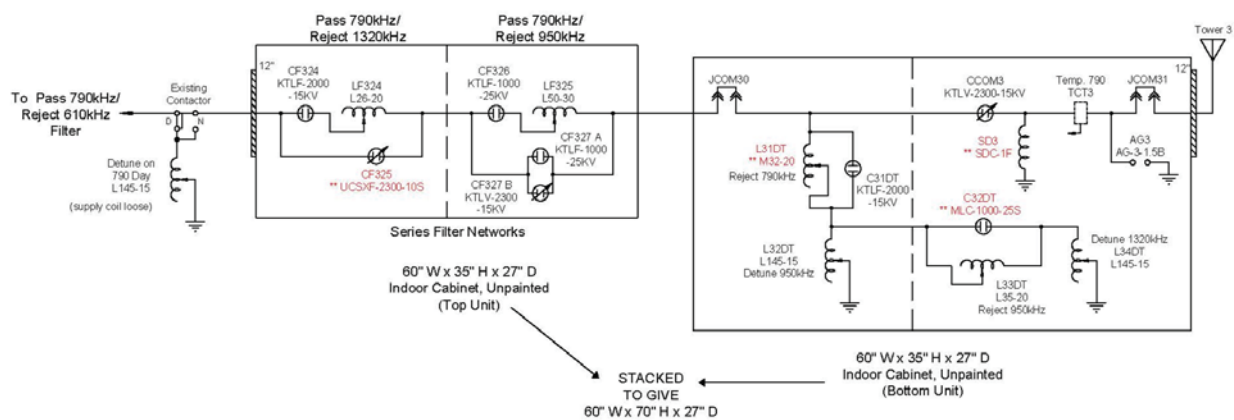

NOTES:

- ** Indicates customer - supplied surplus part.

 KINTRONIC LABORATORIES INC. BLUFF CITY, TN. COPYRIGHT 2021 KINTRONIC LABORATORIES INC.		FREQ:	KPRC KXYZ onto KBME Tower #3 RF SCHEMATIC HOUSTON, TX		
		POWER:			
		DESIGNED:			
REV. 02	REV. DESCRIPTION:	REV. DATE: 27-JULY-21	JOB NO: 118488	DESIGNED: B.Cox	THE CONTENTS OF THIS DRAWING ARE THE INTELLECTUAL PROPERTY OF KINTRONIC LABS, INC. AND ARE NOT TO BE DISTRIBUTED TO ANY THIRD PARTY WITHOUT THE WRITTEN CONSENT OF KINTRONIC LABS, INC.
DWG NO: 12337-RFS-03	REF DWG.	DATE: 06-JULY-21	DRAWN: N.Ormes	APPROVED:	

Figure 11
Sheet 3 of 8

Tower #4 Parameters

KBME	
Impedance	50.7 + j149.0
Power	842.2
Current (RMS)	4 n
Voltage (RMS)	664.0

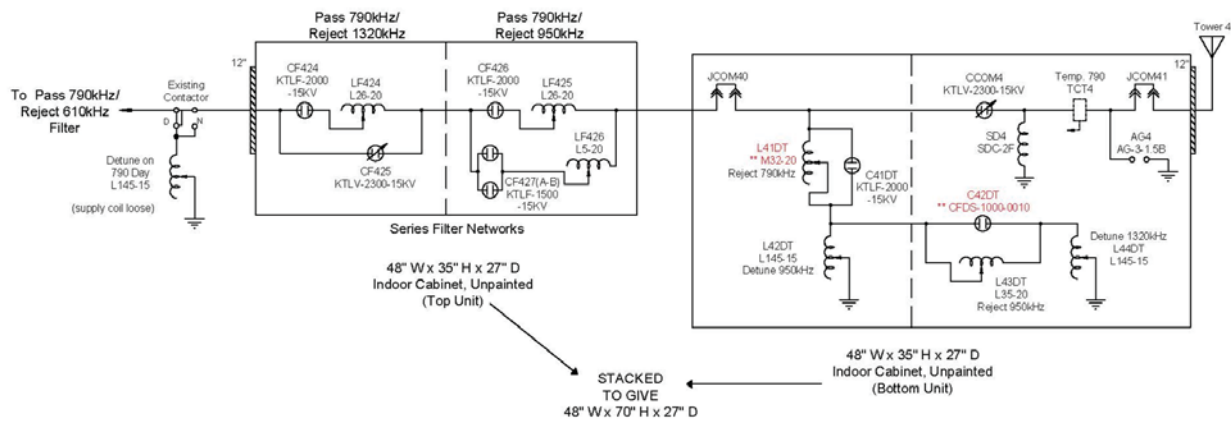

NOTES:

- ** Indicates customer - supplied surplus part.

 <p>KINTRONIC LABORATORIES INC. BLUFF CITY, TN. COPYRIGHT 2021 KINTRONIC LABORATORIES INC.</p>	FREQ:	KPRC KXYZ onto KBME Tower #4 RF SCHEMATIC HOUSTON, TX	
	Varies		
	POWER:		
02	REV. DESCRIPTION:	DESIGNED:	THE CONTENTS OF THIS DRAWING ARE THE INTELLECTUAL PROPERTY OF KINTRONIC LABS, INC. AND ARE NOT TO BE DISTRIBUTED TO ANY THIRD PARTY WITHOUT THE WRITTEN CONSENT OF KINTRONIC LABS, INC.
DWG NO:	REV. DATE:	DESIGNED:	
12337-RFS-04	06-JULY-21	N.Ormes	

Figure 11
Sheet 4 of 8

Tower #5 Parameters

KBME	
Impedance	30.0 + j86.3
Power	1246.0
Current (RMS)	6.6
Voltage (RMS)	598.0

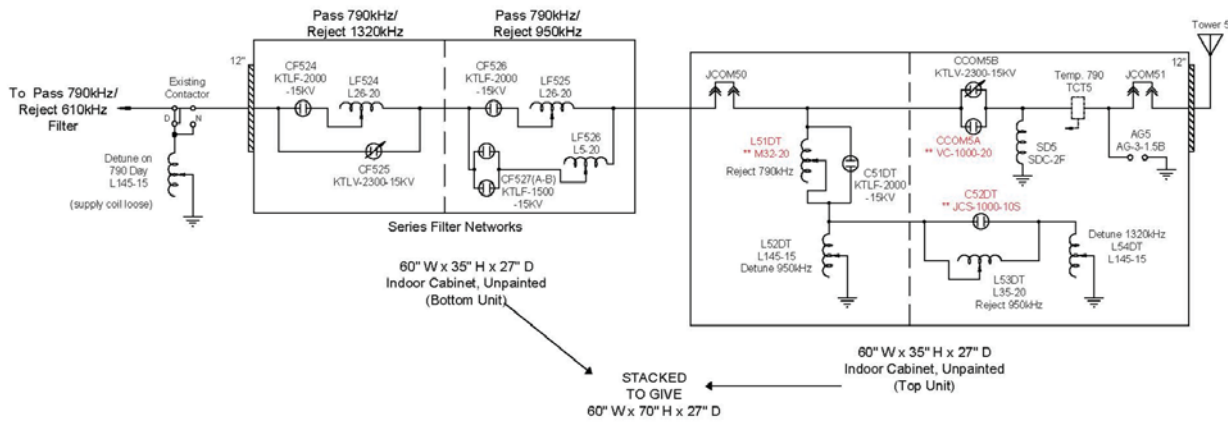

NOTES:
 1. ** Indicates customer - supplied surplus part.

 KINTRONIC LABORATORIES INC. BLUFF CITY, TN. COPYRIGHT 2021 KINTRONIC LABORATORIES INC.		FREQ:	KPRC KXYZ onto KBME Tower #5 RF SCHEMATIC HOUSTON, TX		
		Varies			
POWER:	Varies				
REV. 02	REV. DESCRIPTION:	REV. DATE: 27-JULY-21	JOB NO: 118488	DESIGNED: B.Cox	THE CONTENTS OF THIS DRAWING ARE THE INTELLECTUAL PROPERTY OF KINTRONIC LABS, INC. AND ARE NOT TO BE DISTRIBUTED TO ANY THIRD PARTY WITHOUT THE WRITTEN CONSENT OF KINTRONIC LABS, INC.
DWG NO: 12337-RFS-05	REF DWG.	DATE: 06-JULY-21	DRAWN: N.Ormes	APPROVED:	

Figure 11
Sheet 5 of 8



KINTRONIC LABORATORIES INC.
BLUFF CITY, TN.

COPYRIGHT 2021 KINTRONIC LABORATORIES INC.

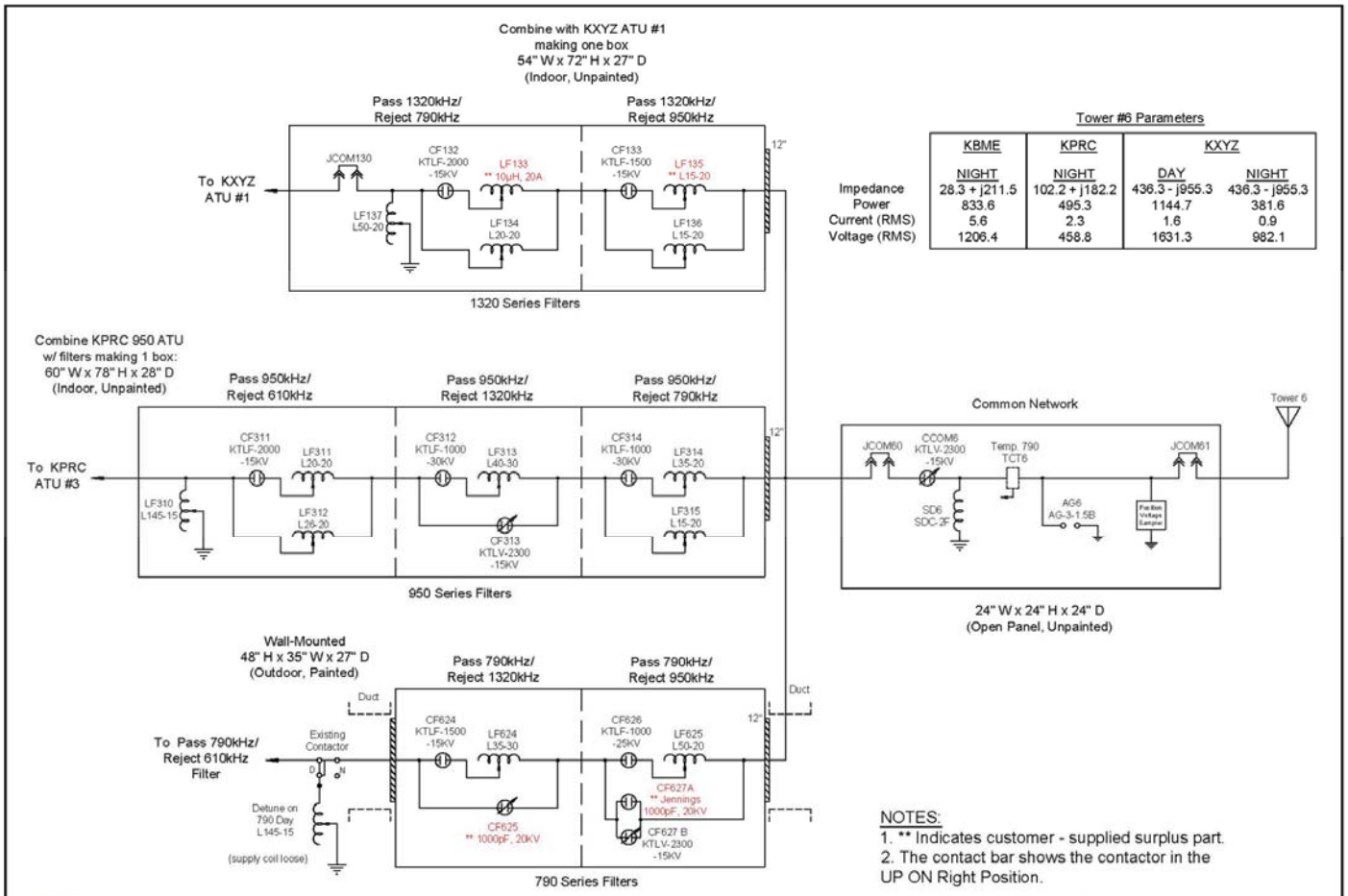
FREQ:	KPRC KXYZ onto KBME Tower #6 RF SCHEMATIC HOUSTON, TX			
Varies				
POWER:	THE CONTENTS OF THIS DRAWING ARE THE INTELLECTUAL PROPERTY OF KINTRONIC LABS, INC. AND ARE NOT TO BE DISTRIBUTED TO ANY THIRD PARTY WITHOUT THE WRITTEN CONSENT OF KINTRONIC LABS, INC.			
Varies				
REV. 06	REV. DESCRIPTION: Removed 1320 Voltage Sampler & Edited Com. Network Pos. Voltage Sample	REV. DATE: 24-OCT-22	JOB NO: 118488	DESIGNED: B.Cox
DWG NO: 12337-RFS-06	REF DWG.	DATE: 07-JULY-21	DRAWN: N.Ormes	APPROVED:

Figure 11
Sheet 6 of 8

NOTES:

1. ** Indicates customer - surplus part.

Top Unit Mounted atop 1320 ATU
54" W x 35" H x 27" D
(Outdoor, Painted)

Tower #7 Parameters

	KBME		KXYZ		ND #2
	DAY	NIGHT	DAY	NIGHT	
Impedance	118.1 + j79.7	-14.6 + j134.0	404.2 - j388.4	404.2 - j388.4	487.5 - j500.8
Power	1912.9	746.5	5770.3	1923.4	2100.0
Current (RMS)	4.0	7.6	3.8	2.2	2.1
Voltage (RMS)	573.5	1013.1	2118.0	1222.8	1495.6

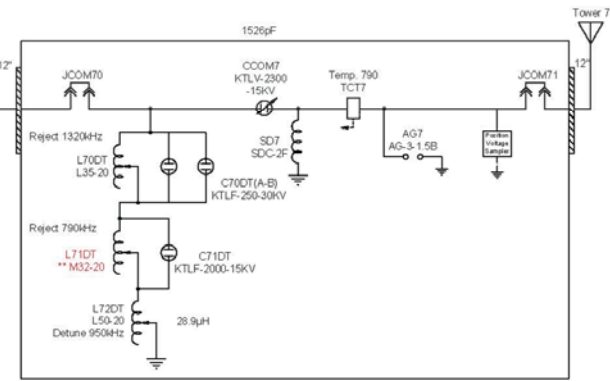
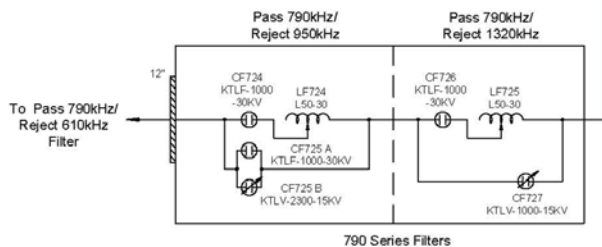
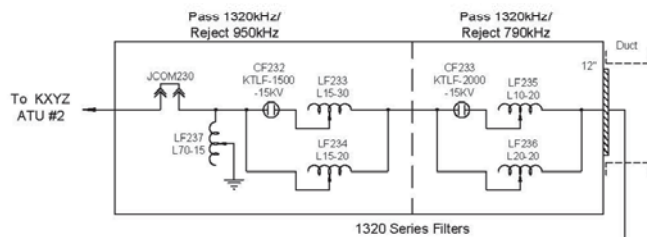

48" W x 40" H x 27" D Indoor Cabinet, Unpainted (Bottom Unit)
48" W x 35" H x 27" D Indoor Cabinet, Unpainted (Top Unit)
STACKED TO GIVE 48" W x 75" H x 27" D

 <p>KINTRONIC LABORATORIES INC. BLUFF CITY, TN. COPYRIGHT 2021 KINTRONIC LABORATORIES INC.</p>	FREQ:	<p>KPRC KXYZ onto KBME Tower #7 RF SCHEMATIC HOUSTON, TX</p>	
	Varies		
POWER:	Varies	<p>THE CONTENTS OF THIS DRAWING ARE THE INTELLECTUAL PROPERTY OF KINTRONIC LABS, INC. AND ARE NOT TO BE DISTRIBUTED TO ANY THIRD PARTY WITHOUT THE WRITTEN CONSENT OF KINTRONIC LABS, INC.</p>	
DESIGNED:	B.Cox		
DRAWN:	N.Ormes		
REV. 05	REV. DESCRIPTION: Removed 1320 Voltage Sampler & Edited Com. Network Pos. Voltage Sampler	REV. DATE: 24-OCT-22	JOB NO: 118488
DWG NO: 12337-RFS-07	REF DWG.	DATE: 07-JULY-21	DRAWN: N.Ormes

Figure 11
Sheet 7 of 8



NOTES:
1. ** Indicates customer - supplied surplus part.

	KINTRONIC LABORATORIES INC. BLUFF CITY, TN. <small>COPYRIGHT 2021 KINTRONIC LABORATORIES INC.</small>	FREQ: Varies	KPRC KXYZ onto KBME Tower #8 RF SCHEMATIC HOUSTON, TX
	REV. 06 REV. DESCRIPTION: <small>Removed 1320 Voltage Sampler & Edited Com. Network Pos. Voltage Sampler</small>	REV. DATE: 24-OCT-22	
DWG NO: 12337-RFS-08	REF DWG.	DATE: 07-JULY-21	DRAWN: N.Ormes
		DESIGNED: B.Cox	THE CONTENTS OF THIS DRAWING ARE THE INTELLECTUAL PROPERTY OF KINTRONIC LABS, INC. AND ARE NOT TO BE DISTRIBUTED TO ANY THIRD PARTY WITHOUT THE WRITTEN CONSENT OF KINTRONIC LABS, INC.

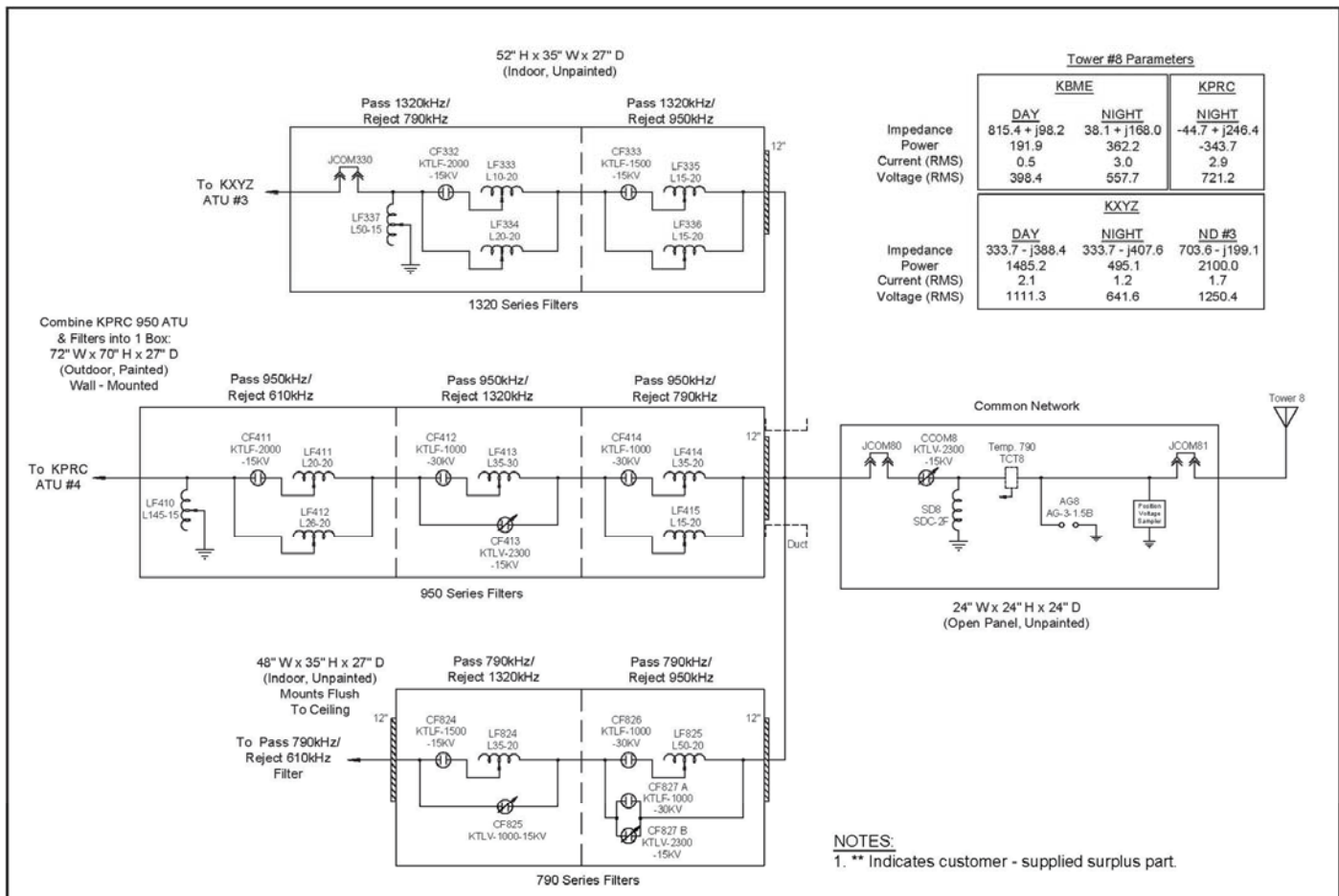
Figure 11
Sheet 8 of 8

APPENDIX A

INDIVIDUAL TOWER MODEL

**APPENDIX A – INDIVIDUAL TOWER MODEL
STATION KBME – HOUSTON, TEXAS**

IMPEDANCE - TOWER #1

normalization = 50.
 freq resist react impd phase VSWR S11 S12
 (MHz) (ohms) (ohms) (ohms) (deg) dB dB
 source = 1; node 1, sector 1
 .79 67.913 94.452 116.33 54.3 4.4995 -3.9264 -2.2542

GEOMETRY - TOWER #1

Wire coordinates in degrees; other dimensions in meters
 Environment: perfect ground

wire	caps	Distance	Angle	Z	radius	segs
1	none	0	0	0	.2911	24
		0	0	102.03		
2	none	100.	175.	0	.2911	24
		100.	175.	104.58		
3	none	200.	175.	0	.2911	24
		200.	175.	105.47		
4	none	300.	175.	0	.2911	24
		300.	175.	101.85		
5	none	194.	45.	0	.2358	24
		194.	45.	103.21		
6	none	150.7	75.6	0	.2911	24
		150.7	75.6	105.57		
7	none	166.6	111.9	0	.2911	24
		166.6	111.9	106.06		
8	none	229.8	134.7	0	.2911	24
		229.8	134.7	103.6		

Number of wires = 8
 current nodes = 192

Individual wires segment length radius	minimum		maximum	
	wire	value	wire	value
	4	4.24375	7	4.41917
	5	.2358	1	.2911

ELECTRICAL DESCRIPTION - TOWER #1

Frequencies (MHz)

no.	lowest	step	no. of steps	segment length (wavelengths)	
				minimum	maximum
1	.79	0	1	.0117882	.0122755

Sources

source	node	sector	magnitude	phase	type
1	1	1	1.	0	voltage

Lumped loads

load	node	resistance (ohms)	reactance (ohms)	inductance (mH)	capacitance (uF)	passive circuit
1	1	1.E-03	0	0	0	0
2	25	1.E-03	0	0	1.5E-05	0
3	49	1.E-03	0	0	1.5E-05	0
4	73	1.E-03	0	0	1.5E-05	0
5	97	1.E-03	0	0	1.5E-05	0
6	121	1.E-03	0	0	1.5E-05	0
7	145	1.E-03	0	0	1.5E-05	0
8	169	1.E-03	0	0	1.5E-05	0

**APPENDIX A – INDIVIDUAL TOWER MODEL
STATION KBME – HOUSTON, TEXAS**

IMPEDANCE - TOWER #2

normalization = 50.
 freq resist react impd phase VSWR S11 S12
 (MHz) (ohms) (ohms) (ohms) (deg) dB dB
 source = 1; node 25, sector 1
 .79 71.599 111.46 132.47 57.3 5.4158 -3.2448 -2.7878

GEOMETRY - TOWER #2

Wire coordinates in degrees; other dimensions in meters
 Environment: perfect ground

wire	caps	Distance	Angle	Z	radius	segs
1	none	0	0	0	.2911	24
		0	0	102.03		
2	none	100.	175.	0	.2911	24
		100.	175.	104.58		
3	none	200.	175.	0	.2911	24
		200.	175.	105.47		
4	none	300.	175.	0	.2911	24
		300.	175.	101.85		
5	none	194.	45.	0	.2358	24
		194.	45.	103.21		
6	none	150.7	75.6	0	.2911	24
		150.7	75.6	105.57		
7	none	166.6	111.9	0	.2911	24
		166.6	111.9	106.06		
8	none	229.8	134.7	0	.2911	24
		229.8	134.7	103.6		

Number of wires = 8
 current nodes = 192

Individual wires	minimum		maximum	
	wire	value	wire	value
segment length	4	4.24375	7	4.41917
radius	5	.2358	1	.2911

ELECTRICAL DESCRIPTION - TOWER #2

Frequencies (MHz)

no.	lowest	step	no. of steps	segment length (wavelengths)	
				minimum	maximum
1	.79	0	1	.0117882	.0122755

Sources

source	node	sector	magnitude	phase	type
1	25	1	1.	0	voltage

Lumped loads

load	node	resistance (ohms)	reactance (ohms)	inductance (mH)	capacitance (uF)	passive circuit
1	1	1.E-03	0	0	1.5E-05	0
2	25	1.E-03	0	0	0	0
3	49	1.E-03	0	0	1.5E-05	0
4	73	1.E-03	0	0	1.5E-05	0
5	97	1.E-03	0	0	1.5E-05	0
6	121	1.E-03	0	0	1.5E-05	0
7	145	1.E-03	0	0	1.5E-05	0
8	169	1.E-03	0	0	1.5E-05	0

**APPENDIX A – INDIVIDUAL TOWER MODEL
STATION KBME – HOUSTON, TEXAS**

IMPEDANCE - TOWER #3

normalization = 50.
 freq resist react imped phase VSWR S11 S12
 (MHz) (ohms) (ohms) (ohms) (deg) dB dB
 source = 1; node 49, sector 1
 .79 73.486 116.73 137.93 57.8 5.6824 -3.0893 -2.9327

GEOMETRY - TOWER #3

Wire coordinates in degrees; other dimensions in meters
 Environment: perfect ground

wire	caps	Distance	Angle	Z	radius	segs
1	none	0	0	0	.2911	24
		0	0	102.03		
2	none	100.	175.	0	.2911	24
		100.	175.	104.58		
3	none	200.	175.	0	.2911	24
		200.	175.	105.47		
4	none	300.	175.	0	.2911	24
		300.	175.	101.85		
5	none	194.	45.	0	.2358	24
		194.	45.	103.21		
6	none	150.7	75.6	0	.2911	24
		150.7	75.6	105.57		
7	none	166.6	111.9	0	.2911	24
		166.6	111.9	106.06		
8	none	229.8	134.7	0	.2911	24
		229.8	134.7	103.6		

Number of wires = 8
 current nodes = 192

Individual wires	minimum		maximum	
	wire	value	wire	value
segment length	4	4.24375	7	4.41917
radius	5	.2358	1	.2911

ELECTRICAL DESCRIPTION - TOWER #3

Frequencies (MHz)

no.	lowest	step	no. of steps	segment length (wavelengths)	
				minimum	maximum
1	.79	0	1	.0117882	.0122755

Sources

source	node	sector	magnitude	phase	type
1	49	1	1.	0	voltage

Lumped loads

load	node	resistance (ohms)	reactance (ohms)	inductance (mH)	capacitance (uF)	passive circuit
1	1	1.E-03	0	0	1.5E-05	0
2	25	1.E-03	0	0	1.5E-05	0
3	49	1.E-03	0	0	0	0
4	73	1.E-03	0	0	1.5E-05	0
5	97	1.E-03	0	0	1.5E-05	0
6	121	1.E-03	0	0	1.5E-05	0
7	145	1.E-03	0	0	1.5E-05	0
8	169	1.E-03	0	0	1.5E-05	0

**APPENDIX A – INDIVIDUAL TOWER MODEL
STATION KBME – HOUSTON, TEXAS**

IMPEDANCE - TOWER #4

normalization = 50.
 freq resist react imped phase VSWR S11 S12
 (MHz) (ohms) (ohms) (ohms) (deg) dB dB
 source = 1; node 73, sector 1
 .79 64.794 91.432 112.06 54.7 4.4218 -3.9977 -2.2063

GEOMETRY - TOWER #4

Wire coordinates in degrees; other dimensions in meters
 Environment: perfect ground

wire	caps	Distance	Angle	Z	radius	segs
1	none	0	0	0	.2911	24
		0	0	102.03		
2	none	100.	175.	0	.2911	24
		100.	175.	104.58		
3	none	200.	175.	0	.2911	24
		200.	175.	105.47		
4	none	300.	175.	0	.2911	24
		300.	175.	101.85		
5	none	194.	45.	0	.2358	24
		194.	45.	103.21		
6	none	150.7	75.6	0	.2911	24
		150.7	75.6	105.57		
7	none	166.6	111.9	0	.2911	24
		166.6	111.9	106.06		
8	none	229.8	134.7	0	.2911	24
		229.8	134.7	103.6		

Number of wires = 8
 current nodes = 192

Individual wires segment length radius	minimum		maximum	
	wire	value	wire	value
	4	4.24375	7	4.41917
	5	.2358	1	.2911

ELECTRICAL DESCRIPTION - TOWER #4

Frequencies (MHz)

no.	lowest	step	no. of steps	segment length (wavelengths)	
				minimum	maximum
1	.79	0	1	.0117882	.0122755

Sources

source	node	sector	magnitude	phase	type
1	73	1	1.	0	voltage

Lumped loads

load	node	resistance (ohms)	reactance (ohms)	inductance (mH)	capacitance (uF)	passive circuit
1	1	1.E-03	0	0	1.5E-05	0
2	25	1.E-03	0	0	1.5E-05	0
3	49	1.E-03	0	0	1.5E-05	0
4	73	1.E-03	0	0	0	0
5	97	1.E-03	0	0	1.5E-05	0
6	121	1.E-03	0	0	1.5E-05	0
7	145	1.E-03	0	0	1.5E-05	0
8	169	1.E-03	0	0	1.5E-05	0

**APPENDIX A – INDIVIDUAL TOWER MODEL
STATION KBME – HOUSTON, TEXAS**

IMPEDANCE - TOWER #5

normalization = 50.
 freq resist react imped phase VSWR S11 S12
 (MHz) (ohms) (ohms) (ohms) (deg) dB dB
 source = 1; node 97, sector 1
 .79 67.581 102.95 123.15 56.7 5.0294 -3.5007 -2.5697

GEOMETRY - TOWER #5

Wire coordinates in degrees; other dimensions in meters
 Environment: perfect ground

wire	caps	Distance	Angle	Z	radius	segs
1	none	0	0	0	.2911	24
		0	0	102.03		
2	none	100.	175.	0	.2911	24
		100.	175.	104.58		
3	none	200.	175.	0	.2911	24
		200.	175.	105.47		
4	none	300.	175.	0	.2911	24
		300.	175.	101.85		
5	none	194.	45.	0	.2358	24
		194.	45.	103.21		
6	none	150.7	75.6	0	.2911	24
		150.7	75.6	105.57		
7	none	166.6	111.9	0	.2911	24
		166.6	111.9	106.06		
8	none	229.8	134.7	0	.2911	24
		229.8	134.7	103.6		

Number of wires = 8
 current nodes = 192

Individual wires segment length radius	minimum		maximum	
	wire	value	wire	value
	4	4.24375	7	4.41917
	5	.2358	1	.2911

ELECTRICAL DESCRIPTION - TOWER #5

Frequencies (MHz)

no.	lowest	step	no. of steps	segment length (wavelengths)	
				minimum	maximum
1	.79	0	1	.0117882	.0122755

Sources

source	node	sector	magnitude	phase	type
1	97	1	1.	0	voltage

Lumped loads

load	node	resistance (ohms)	reactance (ohms)	inductance (mH)	capacitance (uF)	passive circuit
1	1	1.E-03	0	0	1.5E-05	0
2	25	1.E-03	0	0	1.5E-05	0
3	49	1.E-03	0	0	1.5E-05	0
4	73	1.E-03	0	0	1.5E-05	0
5	97	1.E-03	0	0	0	0
6	121	1.E-03	0	0	1.5E-05	0
7	145	1.E-03	0	0	1.5E-05	0
8	169	1.E-03	0	0	1.5E-05	0

**APPENDIX A – INDIVIDUAL TOWER MODEL
STATION KBME – HOUSTON, TEXAS**

IMPEDANCE - TOWER #6

normalization = 50.
 freq resist react impd phase VSWR S11 S12
 (MHz) (ohms) (ohms) (ohms) (deg) dB dB
 source = 1; node 121, sector 1
 .79 73.642 117.33 138.53 57.9 5.7157 -3.0709 -2.9505

GEOMETRY - TOWER #6

Wire coordinates in degrees; other dimensions in meters
 Environment: perfect ground

wire	caps	Distance	Angle	Z	radius	segs
1	none	0	0	0	.2911	24
		0	0	102.03		
2	none	100.	175.	0	.2911	24
		100.	175.	104.58		
3	none	200.	175.	0	.2911	24
		200.	175.	105.47		
4	none	300.	175.	0	.2911	24
		300.	175.	101.85		
5	none	194.	45.	0	.2358	24
		194.	45.	103.21		
6	none	150.7	75.6	0	.2911	24
		150.7	75.6	105.57		
7	none	166.6	111.9	0	.2911	24
		166.6	111.9	106.06		
8	none	229.8	134.7	0	.2911	24
		229.8	134.7	103.6		

Number of wires = 8
 current nodes = 192

Individual wires	minimum		maximum	
	wire	value	wire	value
segment length	4	4.24375	7	4.41917
radius	5	.2358	1	.2911

ELECTRICAL DESCRIPTION - TOWER #6

Frequencies (MHz)

no.	lowest	step	no. of steps	segment length (wavelengths)	
				minimum	maximum
1	.79	0	1	.0117882	.0122755

Sources

source	node	sector	magnitude	phase	type
1	121	1	1.	0	voltage

Lumped loads

load	node	resistance (ohms)	reactance (ohms)	inductance (mH)	capacitance (uF)	passive circuit
1	1	1.E-03	0	0	1.5E-05	0
2	25	1.E-03	0	0	1.5E-05	0
3	49	1.E-03	0	0	1.5E-05	0
4	73	1.E-03	0	0	1.5E-05	0
5	97	1.E-03	0	0	1.5E-05	0
6	121	1.E-03	0	0	0	0
7	145	1.E-03	0	0	1.5E-05	0
8	169	1.E-03	0	0	1.5E-05	0

**APPENDIX A – INDIVIDUAL TOWER MODEL
STATION KBME – HOUSTON, TEXAS**

IMPEDANCE - TOWER #7

normalization = 50.
 freq resist react impd phase VSWR S11 S12
 (MHz) (ohms) (ohms) (ohms) (deg) dB dB
 source = 1; node 145, sector 1
 .79 75.718 121.29 142.99 58. 5.8908 -2.9778 -3.0431

GEOMETRY - TOWER #7

Wire coordinates in degrees; other dimensions in meters
 Environment: perfect ground

wire	caps	Distance	Angle	Z	radius	segs
1	none	0	0	0	.2911	24
		0	0	102.03		
2	none	100.	175.	0	.2911	24
		100.	175.	104.58		
3	none	200.	175.	0	.2911	24
		200.	175.	105.47		
4	none	300.	175.	0	.2911	24
		300.	175.	101.85		
5	none	194.	45.	0	.2358	24
		194.	45.	103.21		
6	none	150.7	75.6	0	.2911	24
		150.7	75.6	105.57		
7	none	166.6	111.9	0	.2911	24
		166.6	111.9	106.06		
8	none	229.8	134.7	0	.2911	24
		229.8	134.7	103.6		

Number of wires = 8
 current nodes = 192

Individual wires	minimum		maximum	
	wire	value	wire	value
segment length	4	4.24375	7	4.41917
radius	5	.2358	1	.2911

ELECTRICAL DESCRIPTION - TOWER #7

Frequencies (MHz)

no.	lowest	step	no. of steps	segment length (wavelengths)	
				minimum	maximum
1	.79	0	1	.0117882	.0122755

Sources

source	node	sector	magnitude	phase	type
1	145	1	1.	0	voltage

Lumped loads

load	node	resistance (ohms)	reactance (ohms)	inductance (mH)	capacitance (uF)	passive circuit
1	1	1.E-03	0	0	1.5E-05	0
2	25	1.E-03	0	0	1.5E-05	0
3	49	1.E-03	0	0	1.5E-05	0
4	73	1.E-03	0	0	1.5E-05	0
5	97	1.E-03	0	0	1.5E-05	0
6	121	1.E-03	0	0	1.5E-05	0
7	145	1.E-03	0	0	0	0
8	169	1.E-03	0	0	1.5E-05	0

**APPENDIX A – INDIVIDUAL TOWER MODEL
STATION KBME – HOUSTON, TEXAS**

IMPEDANCE - TOWER #8

normalization = 50.
 freq resist react imped phase VSWR S11 S12
 (MHz) (ohms) (ohms) (ohms) (deg) dB dB
 source = 1; node 169, sector 1
 .79 72.153 104.57 127.05 55.4 4.9657 -3.5468 -2.5328

GEOMETRY - TOWER #8

Wire coordinates in degrees; other dimensions in meters
 Environment: perfect ground

wire	caps	Distance	Angle	Z	radius	segs
1	none	0	0	0	.2911	24
		0	0	102.03		
2	none	100.	175.	0	.2911	24
		100.	175.	104.58		
3	none	200.	175.	0	.2911	24
		200.	175.	105.47		
4	none	300.	175.	0	.2911	24
		300.	175.	101.85		
5	none	194.	45.	0	.2358	24
		194.	45.	103.21		
6	none	150.7	75.6	0	.2911	24
		150.7	75.6	105.57		
7	none	166.6	111.9	0	.2911	24
		166.6	111.9	106.06		
8	none	229.8	134.7	0	.2911	24
		229.8	134.7	103.6		

Number of wires = 8
 current nodes = 192

Individual wires segment length radius	minimum		maximum	
	wire	value	wire	value
	4	4.24375	7	4.41917
	5	.2358	1	.2911

ELECTRICAL DESCRIPTION - TOWER #8

Frequencies (MHz)

no.	lowest	step	no. of steps	segment length (wavelengths)	
				minimum	maximum
1	.79	0	1	.0117882	.0122755

Sources

source	node	sector	magnitude	phase	type
1	169	1	1.	0	voltage

Lumped loads

load	node	resistance (ohms)	reactance (ohms)	inductance (mH)	capacitance (uF)	passive circuit
1	1	1.E-03	0	0	1.5E-05	0
2	25	1.E-03	0	0	1.5E-05	0
3	49	1.E-03	0	0	1.5E-05	0
4	73	1.E-03	0	0	1.5E-05	0
5	97	1.E-03	0	0	1.5E-05	0
6	121	1.E-03	0	0	1.5E-05	0
7	145	1.E-03	0	0	1.5E-05	0
8	169	1.E-03	0	0	0	0

APPENDIX B

DAYTIME DIRECTIONAL ARRAY MODEL

IMPEDANCE - DAYTIME OPERATION

normalization = 50.

freq (MHz)	resist (ohms)	react (ohms)	imped (ohms)	phase (deg)	VSWR	S11 dB	S12 dB
source = 1; node 1, sector 1							
.79	46.258	98.769	109.06	64.9	6.0588	-2.8937	-3.1302
source = 2; node 25, sector 1							
.79	239.23	238.93	338.11	45.	9.6628	-1.8043	-4.6858
source = 3; node 145, sector 1							
.79	120.18	82.296	145.66	34.4	3.6746	-4.8497	-1.7222
source = 4; node 169, sector 1							
.79	865.15	-27.097	865.57	358.2	17.32	-1.0041	-6.8524

GEOMETRY - DAYTIME OPERATION

Wire coordinates in degrees; other dimensions in meters
Environment: perfect ground

wire	caps	Distance	Angle	Z	radius	segs
1	none	0	0	0	.2911	24
		0	0	102.03		
2	none	100.	175.	0	.2911	24
		100.	175.	104.58		
3	none	200.	175.	0	.2911	24
		200.	175.	105.47		
4	none	300.	175.	0	.2911	24
		300.	175.	101.85		
5	none	194.	45.	0	.2358	24
		194.	45.	103.21		
6	none	150.7	75.6	0	.2911	24
		150.7	75.6	105.57		
7	none	166.6	111.9	0	.2911	24
		166.6	111.9	106.06		
8	none	229.8	134.7	0	.2911	24
		229.8	134.7	103.6		

Number of wires = 8
current nodes = 192

Individual wires	minimum		maximum	
	wire	value	wire	value
segment length	4	4.24375	7	4.41917
radius	5	.2358	1	.2911

ELECTRICAL DESCRIPTION - DAYTIME OPERATION

Frequencies (MHz)

no.	frequency		no. of steps	segment length (wavelengths)	
	lowest	step		minimum	maximum
1	.79	0	1	.0117882	.0122755

Sources

source	node	sector	magnitude	phase	type
1	1	1	1,153.98	69.5	voltage
2	25	1	530.504	301.5	voltage
3	145	1	823.063	308.8	voltage
4	169	1	587.9	203.4	voltage

Lumped loads

load	node	resistance (ohms)	reactance (ohms)	inductance (mH)	capacitance (uF)	passive circuit
1	1	1.E-03	0	0	0	0
2	25	1.E-03	0	0	0	0
3	49	1.E-03	0	.09	0	0
4	73	1.E-03	0	.094	0	0
5	97	1.E-03	0	.098	0	0
6	121	1.E-03	0	.09	0	0
7	145	1.E-03	0	0	0	0
8	169	1.E-03	0	0	0	0

RMS CURRENT - DAYTIME OPERATION

Frequency = .79 MHz
 Input power = 5,000. watts
 Efficiency = 100. %
 coordinates in degrees

current no.	X	Y	Z	mag (amps)	phase (deg)	real (amps)	imaginary (amps)
GND	0	0	0	7.48019	4.6	7.45614	.599333
2	0	0	4.25125	7.82737	3.4	7.81393	.458497
3	0	0	8.5025	8.01095	2.6	8.00255	.366761
4	0	0	12.7538	8.12486	2.	8.11977	.287727
5	0	0	17.005	8.17999	1.5	8.1771	.217227
6	0	0	21.2563	8.18116	1.1	8.17972	.153543
7	0	0	25.5075	8.13108	.7	8.13051	.0958947
8	0	0	29.7588	8.03159	.3	8.03147	.043905
9	0	0	34.01	7.88414	360.	7.88413	-2.61E-03
10	0	0	38.2613	7.69006	359.7	7.68993	-.0437408
11	0	0	42.5125	7.45091	359.4	7.45048	-.0795087
12	0	0	46.7638	7.16797	359.1	7.16713	-.109917
13	0	0	51.015	6.84279	358.9	6.84146	-.134954
14	0	0	55.2663	6.47704	358.6	6.4752	-.154605
15	0	0	59.5175	6.07239	358.4	6.07004	-.168862
16	0	0	63.7688	5.63057	358.2	5.62777	-.177717
17	0	0	68.02	5.15334	358.	5.15015	-.181172
18	0	0	72.2713	4.64238	357.8	4.63892	-.179231
19	0	0	76.5225	4.09923	357.6	4.09563	-.171899
20	0	0	80.7738	3.52507	357.4	3.52147	-.159166
21	0	0	85.025	2.92037	357.2	2.91696	-.140986
22	0	0	89.2763	2.28413	357.1	2.28112	-.11723
23	0	0	93.5275	1.61196	356.9	1.60958	-.0875483
24	0	0	97.7788	.890725	356.7	.889262	-.0510327
END	0	0	102.03	0	0	0	0
GND	-99.6195	-8.71558	0	1.10925	256.5	-.25828	-1.07876
26	-99.6195	-8.71558	4.3575	1.24524	250.5	-.416179	-1.17363
27	-99.6195	-8.71558	8.715	1.33171	247.3	-.514589	-1.22827
28	-99.6195	-8.71558	13.0725	1.40022	244.9	-.594442	-1.26778
29	-99.6195	-8.71558	17.43	1.45384	243.	-.660511	-1.29513
30	-99.6195	-8.71558	21.7875	1.49376	241.4	-.714812	-1.31162
31	-99.6195	-8.71558	26.145	1.52052	240.1	-.758325	-1.31792
32	-99.6195	-8.71558	30.5025	1.5344	238.9	-.791588	-1.31444
33	-99.6195	-8.71558	34.86	1.53561	237.9	-.81496	-1.30151
34	-99.6195	-8.71558	39.2175	1.52434	237.1	-.828696	-1.2794
35	-99.6195	-8.71558	43.575	1.50078	236.3	-.833016	-1.24836
36	-99.6195	-8.71558	47.9325	1.46517	235.6	-.828131	-1.20868
37	-99.6195	-8.71558	52.29	1.41776	234.9	-.814253	-1.16062
38	-99.6195	-8.71558	56.6475	1.35887	234.4	-.791609	-1.10448
39	-99.6195	-8.71558	61.005	1.28882	233.8	-.760432	-1.04057
40	-99.6195	-8.71558	65.3625	1.20797	233.4	-.72099	-.969213

**APPENDIX B – DAYTIME DIRECTIONAL ARRAY MODEL
STATION KBME – HOUSTON, TEXAS**

41	-99.6195	-8.71558	69.72	1.11672	232.9	-.673535	-.89074
42	-99.6195	-8.71558	74.0775	1.01545	232.5	-.618342	-.805473
43	-99.6195	-8.71558	78.435	.904509	232.1	-.555659	-.713709
44	-99.6195	-8.71558	82.7925	.7842	231.7	-.485694	-.615687
45	-99.6195	-8.71558	87.15	.654661	231.4	-.408553	-.511532
46	-99.6195	-8.71558	91.5075	.515705	231.1	-.324135	-.401109
47	-99.6195	-8.71558	95.865	.366364	230.7	-.231824	-.28369
48	-99.6195	-8.71558	100.223	.203639	230.4	-.129695	-.156997
END	-99.6195	-8.71558	104.58	0	0	0	0
GND	-199.239	-17.4312	0	.523351	284.3	.129453	-.507088
50	-199.239	-17.4312	4.39458	.40574	284.3	.100425	-.393115
51	-199.239	-17.4312	8.78917	.328587	284.4	.0815292	-.318312
52	-199.239	-17.4312	13.1838	.261956	284.4	.0653571	-.253672
53	-199.239	-17.4312	17.5783	.202387	284.6	.0510444	-.195845
54	-199.239	-17.4312	21.9729	.14847	284.9	.0382314	-.143463
55	-199.239	-17.4312	26.3675	.0995766	285.6	.0267489	-.0959167
56	-199.239	-17.4312	30.7621	.0554305	287.3	.0165059	-.0529159
57	-199.239	-17.4312	35.1567	.0161458	297.5	7.45E-03	-.014325
58	-199.239	-17.4312	39.5513	.0199178	91.3	-4.59E-04	.0199125
59	-199.239	-17.4312	43.9458	.0503352	98.3	-7.24E-03	.0498111
60	-199.239	-17.4312	48.3404	.0764667	99.7	-.0129322	.0753652
61	-199.239	-17.4312	52.735	.0981442	100.3	-.017547	.0965628
62	-199.239	-17.4312	57.1296	.11534	100.5	-.0211151	.113391
63	-199.239	-17.4312	61.5242	.128047	100.7	-.0236658	.125841
64	-199.239	-17.4312	65.9188	.13627	100.7	-.0252317	.133914
65	-199.239	-17.4312	70.3133	.140021	100.6	-.0258489	.137615
66	-199.239	-17.4312	74.7079	.13932	100.6	-.0255566	.136956
67	-199.239	-17.4312	79.1025	.134186	100.5	-.0243966	.131949
68	-199.239	-17.4312	83.4971	.124631	100.4	-.0224114	.122599
69	-199.239	-17.4312	87.8917	.110639	100.2	-.0196415	.108882
70	-199.239	-17.4312	92.2863	.0921317	100.1	-.0161194	.0907106
71	-199.239	-17.4312	96.6808	.0688589	99.9	-.011853	.0678311
72	-199.239	-17.4312	101.075	.0401272	99.7	-6.78E-03	.03955
END	-199.239	-17.4312	105.47	0	0	0	0
GND	-298.858	-26.1468	0	.427306	193.4	-.415686	-.0989729
74	-298.858	-26.1468	4.24375	.329092	193.4	-.320125	-.0762991
75	-298.858	-26.1468	8.4875	.265057	193.5	-.257779	-.0616874
76	-298.858	-26.1468	12.7313	.20981	193.6	-.203947	-.0492519
77	-298.858	-26.1468	16.975	.160449	193.8	-.155808	-.0383113
78	-298.858	-26.1468	21.2188	.115781	194.3	-.112199	-.028576
79	-298.858	-26.1468	25.4625	.0752791	195.3	-.0725996	-.0199058
80	-298.858	-26.1468	29.7063	.0387395	198.4	-.0367611	-.0122218
81	-298.858	-26.1468	33.95	7.13E-03	230.2	-4.57E-03	-5.47E-03
82	-298.858	-26.1468	38.1938	.0240297	.9	.0240267	3.74E-04
83	-298.858	-26.1468	42.4375	.0493194	6.2	.0490282	5.35E-03
84	-298.858	-26.1468	46.6813	.0710598	7.7	.0704238	9.49E-03
85	-298.858	-26.1468	50.925	.0891155	8.3	.088191	.0128035
86	-298.858	-26.1468	55.1688	.103448	8.5	.102305	.0153334
87	-298.858	-26.1468	59.4125	.114031	8.6	.11274	.0171053
88	-298.858	-26.1468	63.6563	.120848	8.6	.119477	.0181518
89	-298.858	-26.1468	67.9	.123885	8.6	.122495	.0185077
90	-298.858	-26.1468	72.1438	.123134	8.5	.12178	.0182101
91	-298.858	-26.1468	76.3875	.118579	8.4	.117311	.0172974
92	-298.858	-26.1468	80.6313	.110199	8.2	.109059	.0158089
93	-298.858	-26.1468	84.875	.0979431	8.1	.0969686	.0137821
94	-298.858	-26.1468	89.1188	.0817001	7.9	.0809219	.0112493
95	-298.858	-26.1468	93.3625	.0612039	7.7	.0606486	8.23E-03
96	-298.858	-26.1468	97.6063	.0357877	7.5	.0354802	4.68E-03
END	-298.858	-26.1468	101.85	0	0	0	0
GND	137.179	-137.179	0	.32465	295.2	.137984	-.293867

98	137.179	-137.179	4.30042	.252454	295.2	.107355	-.228491
99	137.179	-137.179	8.60083	.203895	295.2	.0868817	-.184458
100	137.179	-137.179	12.9013	.161912	295.3	.0693088	-.146327
101	137.179	-137.179	17.2017	.124367	295.6	.0537207	-.112166
102	137.179	-137.179	21.5021	.0904068	296.1	.0397433	-.0812026
103	137.179	-137.179	25.8025	.0596542	297.1	.0271999	-.0530922
104	137.179	-137.179	30.1029	.0319604	300.	.0159955	-.0276697
105	137.179	-137.179	34.4033	7.78E-03	321.3	6.07E-03	-4.86E-03
106	137.179	-137.179	38.7038	.0155898	99.6	-2.6E-03	.0153714
107	137.179	-137.179	43.0042	.0345243	106.9	-.0100572	.033027
108	137.179	-137.179	47.3046	.0507955	108.7	-.0163191	.0481027
109	137.179	-137.179	51.605	.0642596	109.5	-.0214098	.0605881
110	137.179	-137.179	55.9054	.0748945	109.8	-.0253538	.0704725
111	137.179	-137.179	60.2058	.0826957	109.9	-.0281777	.077747
112	137.179	-137.179	64.5063	.087667	109.9	-.0299109	.0824066
113	137.179	-137.179	68.8067	.0898163	109.9	-.0305852	.0844483
114	137.179	-137.179	73.1071	.0891566	109.8	-.0302345	.0838735
115	137.179	-137.179	77.4075	.0857001	109.7	-.0288942	.0806823
116	137.179	-137.179	81.7079	.0794527	109.6	-.0265984	.0748682
117	137.179	-137.179	86.0083	.070405	109.4	-.0233773	.0664106
118	137.179	-137.179	90.3088	.0585052	109.2	-.0192493	.0552478
119	137.179	-137.179	94.6092	.0435992	109.	-.0142015	.0412215
120	137.179	-137.179	98.9096	.0252501	108.8	-8.13E-03	.0239041
END	137.179	-137.179	103.21	0	0	0	0
GND	37.4776	-145.966	0	.647643	340.8	.611763	-.212574
122	37.4776	-145.966	4.39875	.502068	340.8	.47426	-.164773
123	37.4776	-145.966	8.7975	.406673	340.9	.384169	-.133406
124	37.4776	-145.966	13.1963	.324401	340.9	.306487	-.10631
125	37.4776	-145.966	17.595	.250961	340.9	.237158	-.0820807
126	37.4776	-145.966	21.9938	.184592	341.	.17452	-.0601429
127	37.4776	-145.966	26.3925	.124501	341.1	.117818	-.0402394
128	37.4776	-145.966	30.7913	.0702974	341.6	.0666843	-.022247
129	37.4776	-145.966	35.19	.0218024	343.7	.0209297	-6.11E-03
130	37.4776	-145.966	39.5888	.0211921	157.2	-.0195383	8.21E-03
131	37.4776	-145.966	43.9875	.0585474	159.3	-.0547644	.020704
132	37.4776	-145.966	48.3863	.0903935	159.7	-.0847707	.0313836
133	37.4776	-145.966	52.785	.116728	159.8	-.109572	.0402434
134	37.4776	-145.966	57.1838	.137562	159.9	-.129181	.0472811
135	37.4776	-145.966	61.5825	.152915	159.9	-.143622	.0524955
136	37.4776	-145.966	65.9813	.162815	159.9	-.152923	.0558881
137	37.4776	-145.966	70.38	.1673	159.9	-.157122	.0574624
138	37.4776	-145.966	74.7788	.166413	159.9	-.156265	.0572232
139	37.4776	-145.966	79.1775	.1602	159.9	-.150399	.055174
140	37.4776	-145.966	83.5763	.148695	159.8	-.13956	.0513127
141	37.4776	-145.966	87.975	.131901	159.8	-.123759	.0456241
142	37.4776	-145.966	92.3738	.109742	159.7	-.10293	.0380626
143	37.4776	-145.966	96.7725	.081943	159.6	-.0768237	.0285093
144	37.4776	-145.966	101.171	.0477023	159.6	-.0447001	.0166557
END	37.4776	-145.966	105.57	0	0	0	0
GND	-62.1398	-154.578	0	3.99477	274.4	.306385	-3.983
146	-62.1398	-154.578	4.41917	4.15757	271.1	.0790336	-4.15682
147	-62.1398	-154.578	8.83833	4.24758	269.1	-.0666623	-4.24706
148	-62.1398	-154.578	13.2575	4.30476	267.5	-.188842	-4.30062
149	-62.1398	-154.578	17.6767	4.33315	266.1	-.294279	-4.32315
150	-62.1398	-154.578	22.0958	4.33441	264.9	-.385772	-4.31721
151	-62.1398	-154.578	26.515	4.30935	263.8	-.46462	-4.28423
152	-62.1398	-154.578	30.9342	4.25853	262.8	-.531498	-4.22523
153	-62.1398	-154.578	35.3533	4.18242	261.9	-.586786	-4.14106
154	-62.1398	-154.578	39.7725	4.08156	261.1	-.63072	-4.03253
155	-62.1398	-154.578	44.1917	3.9565	260.3	-.663467	-3.90047

156	-62.1398	-154.578	48.6108	3.80789	259.6	-.685164	-3.74574
157	-62.1398	-154.578	53.03	3.63648	259.	-.695943	-3.56926
158	-62.1398	-154.578	57.4492	3.44308	258.3	-.69595	-3.37201
159	-62.1398	-154.578	61.8683	3.22857	257.7	-.685342	-3.15499
160	-62.1398	-154.578	66.2875	2.9939	257.2	-.6643	-2.91927
161	-62.1398	-154.578	70.7067	2.74004	256.6	-.633014	-2.66592
162	-62.1398	-154.578	75.1258	2.46795	256.1	-.591686	-2.39597
163	-62.1398	-154.578	79.545	2.17853	255.6	-.540508	-2.11042
164	-62.1398	-154.578	83.9642	1.87252	255.2	-.479634	-1.81005
165	-62.1398	-154.578	88.3833	1.55028	254.7	-.409124	-1.49532
166	-62.1398	-154.578	92.8025	1.21145	254.3	-.328819	-1.16597
167	-62.1398	-154.578	97.2217	.853871	253.8	-.238032	-.820022
168	-62.1398	-154.578	101.641	.470809	253.4	-.134675	-.451136
END	-62.1398	-154.578	106.06	0	0	0	0
GND	-161.64	-163.342	0	.480172	205.2	-.434495	-.204402
170	-161.64	-163.342	4.31667	.515113	181.8	-.514866	-.0159408
171	-161.64	-163.342	8.63333	.572817	169.5	-.563277	.104107
172	-161.64	-163.342	12.95	.634674	161.2	-.600835	.20447
173	-161.64	-163.342	17.2667	.693883	155.2	-.630015	.290784
174	-161.64	-163.342	21.5833	.747307	150.7	-.651884	.365397
175	-161.64	-163.342	25.9	.793254	147.2	-.666982	.429403
176	-161.64	-163.342	30.2167	.830744	144.4	-.675634	.483379
177	-161.64	-163.342	34.5333	.859183	142.1	-.678071	.52765
178	-161.64	-163.342	38.85	.878205	140.2	-.674483	.56242
179	-161.64	-163.342	43.1667	.887598	138.5	-.665043	.587834
180	-161.64	-163.342	47.4833	.887257	137.1	-.649923	.604008
181	-161.64	-163.342	51.8	.877157	135.8	-.629301	.611053
182	-161.64	-163.342	56.1167	.85734	134.7	-.60336	.609089
183	-161.64	-163.342	60.4333	.8279	133.7	-.572299	.598241
184	-161.64	-163.342	64.75	.788974	132.8	-.536321	.578653
185	-161.64	-163.342	69.0667	.740728	132.	-.495636	.550475
186	-161.64	-163.342	73.3833	.683346	131.2	-.450455	.51386
187	-161.64	-163.342	77.7	.617003	130.5	-.400972	.46895
188	-161.64	-163.342	82.0167	.541835	129.9	-.347353	.415849
189	-161.64	-163.342	86.3333	.457873	129.2	-.289698	.354574
190	-161.64	-163.342	90.65	.364915	128.7	-.227961	.28495
191	-161.64	-163.342	94.9667	.262176	128.1	-.161755	.206329
192	-161.64	-163.342	99.2833	.14737	127.5	-.0898021	.116848
END	-161.64	-163.342	103.6	0	0	0	0

APPENDIX C

NIGHTTIME DIRECTIONAL ARRAY MODEL

IMPEDANCE - NIGHTTIME OPERATION

normalization = 50.

freq (MHz)	resist (ohms)	react (ohms)	imped (ohms)	phase (deg)	VSWR	S11 dB	S12 dB
source = 1; node 1, sector 1							
.79	10.223	86.582	87.183	83.3	19.711	-.8821	-7.3563
source = 2; node 25, sector 1							
.79	13.018	169.12	169.62	85.6	48.024	-.36178	-10.973
source = 3; node 49, sector 1							
.79	7.6833	130.33	130.56	86.6	50.858	-.34162	-11.212
source = 4; node 73, sector 1							
.79	53.851	167.9	176.32	72.2	12.394	-1.4047	-5.5855
source = 5; node 97, sector 1							
.79	27.531	89.837	93.961	73.	8.1064	-2.154	-4.078
source = 6; node 121, sector 1							
.79	24.448	200.98	202.46	83.1	35.551	-.48878	-9.7288
source = 7; node 145, sector 1							
.79	-14.451	137.34	138.1	96.	****	****	****
source = 8; node 169, sector 1							
.79	43.118	209.34	213.74	78.4	22.305	-.77936	-7.8443

GEOMETRY - NIGHTTIME OPERATION

Wire coordinates in degrees; other dimensions in meters
Environment: perfect ground

wire	caps	Distance	Angle	Z	radius	segs
1	none	0	0	0	.2911	24
		0	0	102.03		
2	none	100.	175.	0	.2911	24
		100.	175.	104.58		
3	none	200.	175.	0	.2911	24
		200.	175.	105.47		
4	none	300.	175.	0	.2911	24
		300.	175.	101.85		
5	none	194.	45.	0	.2358	24
		194.	45.	103.21		
6	none	150.7	75.6	0	.2911	24
		150.7	75.6	105.57		
7	none	166.6	111.9	0	.2911	24
		166.6	111.9	106.06		
8	none	229.8	134.7	0	.2911	24
		229.8	134.7	103.6		

Number of wires = 8
current nodes = 192

	minimum	maximum
Individual wires	wire value	wire value
segment length	4 4.24375	7 4.41917
radius	5 .2358	1 .2911

**APPENDIX C – NIGHTTIME DIRECTIONAL ARRAY MODEL
STATION KBME – HOUSTON, TEXAS**

ELECTRICAL DESCRIPTION - NIGHTTIME OPERATION

Frequencies (MHz)

no.	frequency	step	no. of steps	segment length (wavelengths) minimum	maximum
1	.79	0	1	.0117882	.0122755

Sources

source	node	sector	magnitude	phase	type
1	1	1	1,086.04	50.3	voltage
2	25	1	1,962.05	247.8	voltage
3	49	1	1,868.34	87.4	voltage
4	73	1	1,009.36	323.8	voltage
5	97	1	908.022	31.6	voltage
6	121	1	1,712.44	236.2	voltage
7	145	1	1,512.69	84.6	voltage
8	169	1	881.371	318.7	voltage

Lumped loads

load	node	resistance (ohms)	reactance (ohms)	inductance (mH)	capacitance (uF)	passive circuit
1	1	1.E-03	0	0	0	0
2	25	1.E-03	0	0	0	0
3	49	1.E-03	0	0	0	0
4	73	1.E-03	0	0	0	0
5	97	1.E-03	0	0	0	0
6	121	1.E-03	0	0	0	0
7	145	1.E-03	0	0	0	0
8	169	1.E-03	0	0	0	0

RMS CURRENT - NIGHTTIME OPERATION

Frequency = .79 MHz

Input power = 5,000. watts

Efficiency = 99.99 %

coordinates in degrees

no.	X	Y	Z	mag (amps)	phase (deg)	real (amps)	imaginary (amps)
GND	0	0	0	8.81474	327.	7.3955	-4.79648
2	0	0	4.25125	9.16928	326.8	7.66892	-5.02626
3	0	0	8.5025	9.34924	326.6	7.80471	-5.1473
4	0	0	12.7538	9.45218	326.5	7.87852	-5.22232
5	0	0	17.005	9.48968	326.3	7.89932	-5.25877
6	0	0	21.2563	9.46699	326.2	7.87123	-5.26
7	0	0	25.5075	9.38719	326.2	7.79672	-5.22786
8	0	0	29.7588	9.25227	326.1	7.67734	-5.16361
9	0	0	34.01	9.06403	326.	7.51459	-5.06829
10	0	0	38.2613	8.82406	325.9	7.30974	-4.94285
11	0	0	42.5125	8.53413	325.9	7.06429	-4.78823
12	0	0	46.7638	8.1959	325.8	6.77958	-4.60544
13	0	0	51.015	7.8112	325.8	6.45715	-4.39547
14	0	0	55.2663	7.38195	325.7	6.09855	-4.15943
15	0	0	59.5175	6.91016	325.7	5.70548	-3.89844
16	0	0	63.7688	6.39789	325.6	5.27962	-3.61368
17	0	0	68.02	5.84719	325.6	4.82266	-3.3063
18	0	0	72.2713	5.26006	325.5	4.33625	-2.97743
19	0	0	76.5225	4.63828	325.5	3.82187	-2.62811
20	0	0	80.7738	3.98327	325.4	3.28067	-2.25913
21	0	0	85.025	3.29563	325.4	2.71315	-1.87083
22	0	0	89.2763	2.5743	325.4	2.11843	-1.46262
23	0	0	93.5275	1.81441	325.3	1.49251	-1.03175
24	0	0	97.7788	1.00131	325.3	.823339	-.569848

**APPENDIX C – NIGHTTIME DIRECTIONAL ARRAY MODEL
STATION KBME – HOUSTON, TEXAS**

END	0	0	102.03	0	0	0	0
GND	-99.6195	-8.71558	0	8.18515	162.2	-7.79339	2.50196
26	-99.6195	-8.71558	4.3575	8.85413	161.9	-8.41404	2.75673
27	-99.6195	-8.71558	8.715	9.2363	161.7	-8.76742	2.90543
28	-99.6195	-8.71558	13.0725	9.50899	161.5	-9.01827	3.01524
29	-99.6195	-8.71558	17.43	9.69321	161.4	-9.18612	3.0941
30	-99.6195	-8.71558	21.7875	9.79814	161.3	-9.27952	3.14546
31	-99.6195	-8.71558	26.145	9.82861	161.2	-9.30302	3.17104
32	-99.6195	-8.71558	30.5025	9.78766	161.1	-9.25943	3.17196
33	-99.6195	-8.71558	34.86	9.67761	161.	-9.15095	3.14901
34	-99.6195	-8.71558	39.2175	9.50062	160.9	-8.97964	3.10287
35	-99.6195	-8.71558	43.575	9.25862	160.9	-8.74733	3.0342
36	-99.6195	-8.71558	47.9325	8.95364	160.8	-8.45593	2.94362
37	-99.6195	-8.71558	52.29	8.5879	160.7	-8.10757	2.83183
38	-99.6195	-8.71558	56.6475	8.16363	160.7	-7.70437	2.69955
39	-99.6195	-8.71558	61.005	7.68316	160.6	-7.24853	2.54751
40	-99.6195	-8.71558	65.3625	7.14906	160.6	-6.7425	2.3765
41	-99.6195	-8.71558	69.72	6.56376	160.5	-6.18858	2.18733
42	-99.6195	-8.71558	74.0775	5.92976	160.5	-5.58915	1.98077
43	-99.6195	-8.71558	78.435	5.24933	160.4	-4.94637	1.75755
44	-99.6195	-8.71558	82.7925	4.52431	160.4	-4.26197	1.51822
45	-99.6195	-8.71558	87.15	3.75567	160.3	-3.5369	1.26309
46	-99.6195	-8.71558	91.5075	2.94247	160.3	-2.7703	.991751
47	-99.6195	-8.71558	95.865	2.07942	160.3	-1.9572	.70238
48	-99.6195	-8.71558	100.223	1.14987	160.2	-1.08198	.389248
END	-99.6195	-8.71558	104.58	0	0	0	0
GND	-199.239	-17.4312	0	10.1262	.8	10.1253	.13675
50	-199.239	-17.4312	4.39458	10.7625	.6	10.762	.10653
51	-199.239	-17.4312	8.78917	11.1153	.4	11.1149	.0865739
52	-199.239	-17.4312	13.1838	11.3539	.3	11.3537	.0692085
53	-199.239	-17.4312	17.5783	11.4985	.3	11.4984	.0535526
54	-199.239	-17.4312	21.9729	11.5581	.2	11.558	.0392528
55	-199.239	-17.4312	26.3675	11.5374	.1	11.5374	.0261587
56	-199.239	-17.4312	30.7621	11.4395	.1	11.4395	.0142061
57	-199.239	-17.4312	35.1567	11.267	0.0	11.267	3.37E-03
58	-199.239	-17.4312	39.5513	11.022	360.	11.022	-6.34E-03
59	-199.239	-17.4312	43.9458	10.7069	359.9	10.7069	-.01491
60	-199.239	-17.4312	48.3404	10.3239	359.9	10.3238	-.0223263
61	-199.239	-17.4312	52.735	9.87531	359.8	9.87527	-.028561
62	-199.239	-17.4312	57.1296	9.36386	359.8	9.3638	-.0335895
63	-199.239	-17.4312	61.5242	8.7922	359.8	8.79212	-.0373878
64	-199.239	-17.4312	65.9188	8.16301	359.7	8.16291	-.0399337
65	-199.239	-17.4312	70.3133	7.47925	359.7	7.47914	-.0412068
66	-199.239	-17.4312	74.7079	6.74369	359.7	6.74357	-.0411886
67	-199.239	-17.4312	79.1025	5.95881	359.6	5.95868	-.039861
68	-199.239	-17.4312	83.4971	5.12672	359.6	5.12658	-.0372041
69	-199.239	-17.4312	87.8917	4.24846	359.6	4.24833	-.0331908
70	-199.239	-17.4312	92.2863	3.32301	359.5	3.3229	-.0277749
71	-199.239	-17.4312	96.6808	2.34444	359.5	2.34434	-.0208604
72	-199.239	-17.4312	101.075	1.29408	359.5	1.29402	-.0122158
END	-199.239	-17.4312	105.47	0	0	0	0
GND	-298.858	-26.1468	0	4.05079	251.6	-1.27975	-3.84333
74	-298.858	-26.1468	4.24375	4.37551	250.2	-1.48284	-4.11659
75	-298.858	-26.1468	8.4875	4.56117	249.4	-1.60421	-4.26975
76	-298.858	-26.1468	12.7313	4.69414	248.8	-1.69768	-4.3764
77	-298.858	-26.1468	16.975	4.7844	248.3	-1.7695	-4.44515
78	-298.858	-26.1468	21.2188	4.83632	247.9	-1.82237	-4.47984
79	-298.858	-26.1468	25.4625	4.85216	247.5	-1.85765	-4.48247
80	-298.858	-26.1468	29.7063	4.83332	247.2	-1.87615	-4.45433
81	-298.858	-26.1468	33.95	4.7809	246.9	-1.87844	-4.39641

**APPENDIX C – NIGHTTIME DIRECTIONAL ARRAY MODEL
STATION KBME – HOUSTON, TEXAS**

82	-298.858	-26.1468	38.1938	4.69581	246.6	-1.86498	-4.30958
83	-298.858	-26.1468	42.4375	4.57895	246.4	-1.83617	-4.19467
84	-298.858	-26.1468	46.6813	4.43121	246.1	-1.79243	-4.05251
85	-298.858	-26.1468	50.925	4.25354	245.9	-1.73416	-3.88398
86	-298.858	-26.1468	55.1688	4.04695	245.8	-1.66182	-3.69001
87	-298.858	-26.1468	59.4125	3.81248	245.6	-1.57587	-3.47155
88	-298.858	-26.1468	63.6563	3.55121	245.4	-1.47677	-3.22959
89	-298.858	-26.1468	67.9	3.26425	245.3	-1.36504	-2.96513
90	-298.858	-26.1468	72.1438	2.95266	245.1	-1.24114	-2.67914
91	-298.858	-26.1468	76.3875	2.61741	245.	-1.10553	-2.37247
92	-298.858	-26.1468	80.6313	2.25923	244.9	-.958536	-2.04581
93	-298.858	-26.1468	84.875	1.87841	244.8	-.800327	-1.69938
94	-298.858	-26.1468	89.1188	1.47429	244.7	-.630645	-1.3326
95	-298.858	-26.1468	93.3625	1.04397	244.6	-.448255	-.942834
96	-298.858	-26.1468	97.6063	.578826	244.5	-.249439	-.522321
END	-298.858	-26.1468	101.85	0	0	0	0
GND	137.179	-137.179	0	6.83825	318.6	5.13245	-4.51881
98	137.179	-137.179	4.30042	7.10262	318.	5.27415	-4.75716
99	137.179	-137.179	8.60083	7.24149	317.5	5.34109	-4.88998
100	137.179	-137.179	12.9013	7.32129	317.2	5.36982	-4.97658
101	137.179	-137.179	17.2017	7.35064	316.9	5.36517	-5.02463
102	137.179	-137.179	21.5021	7.33338	316.6	5.32938	-5.03748
103	137.179	-137.179	25.8025	7.27166	316.4	5.26375	-5.01696
104	137.179	-137.179	30.1029	7.16702	316.2	5.16931	-4.96432
105	137.179	-137.179	34.4033	7.0208	316.	5.04696	-4.88056
106	137.179	-137.179	38.7038	6.83425	315.8	4.8976	-4.7666
107	137.179	-137.179	43.0042	6.60866	315.6	4.72215	-4.62338
108	137.179	-137.179	47.3046	6.34538	315.4	4.5216	-4.45185
109	137.179	-137.179	51.605	6.04585	315.3	4.29699	-4.25302
110	137.179	-137.179	55.9054	5.71161	315.2	4.04944	-4.02797
111	137.179	-137.179	60.2058	5.34426	315.	3.7801	-3.77782
112	137.179	-137.179	64.5063	4.94543	314.9	3.49014	-3.50374
113	137.179	-137.179	68.8067	4.51682	314.8	3.18079	-3.20691
114	137.179	-137.179	73.1071	4.06006	314.6	2.8532	-2.88849
115	137.179	-137.179	77.4075	3.57663	314.5	2.50843	-2.54952
116	137.179	-137.179	81.7079	3.06777	314.4	2.14737	-2.1909
117	137.179	-137.179	86.0083	2.5341	314.3	1.77047	-1.81304
118	137.179	-137.179	90.3088	1.97505	314.2	1.37735	-1.41554
119	137.179	-137.179	94.6092	1.38726	314.1	.965697	-.995954
120	137.179	-137.179	98.9096	.759879	314.	.528016	-.546457
END	137.179	-137.179	103.21	0	0	0	0
GND	37.4776	-145.966	0	5.98503	153.1	-5.33911	2.70453
122	37.4776	-145.966	4.39875	6.57233	152.5	-5.82967	3.03488
123	37.4776	-145.966	8.7975	6.91464	152.1	-6.11349	3.23071
124	37.4776	-145.966	13.1963	7.16614	151.9	-6.31976	3.37849
125	37.4776	-145.966	17.595	7.34506	151.6	-6.46381	3.48841
126	37.4776	-145.966	21.9938	7.45929	151.5	-6.55231	3.56487
127	37.4776	-145.966	26.3925	7.51291	151.3	-6.58872	3.61006
128	37.4776	-145.966	30.7913	7.50845	151.1	-6.57522	3.62535
129	37.4776	-145.966	35.19	7.4478	151.	-6.51348	3.6117
130	37.4776	-145.966	39.5888	7.33261	150.9	-6.40492	3.5699
131	37.4776	-145.966	43.9875	7.16445	150.8	-6.25095	3.50071
132	37.4776	-145.966	48.3863	6.9449	150.6	-6.05297	3.40488
133	37.4776	-145.966	52.785	6.67564	150.5	-5.81247	3.28319
134	37.4776	-145.966	57.1838	6.35844	150.4	-5.53103	3.13648
135	37.4776	-145.966	61.5825	5.99518	150.4	-5.21031	2.96562
136	37.4776	-145.966	65.9813	5.58781	150.3	-4.85203	2.77154
137	37.4776	-145.966	70.38	5.13833	150.2	-4.45798	2.55517
138	37.4776	-145.966	74.7788	4.64871	150.1	-4.02988	2.31744
139	37.4776	-145.966	79.1775	4.12076	150.	-3.56936	2.05921

140	37.4776	-145.966	83.5763	3.55599	149.9	-3.07774	1.78116
141	37.4776	-145.966	87.975	2.95519	149.9	-2.55577	1.48364
142	37.4776	-145.966	92.3738	2.3177	149.8	-2.00291	1.16623
143	37.4776	-145.966	96.7725	1.63938	149.7	-1.41564	.826764
144	37.4776	-145.966	101.171	.907152	149.6	-.782736	.45853
END	37.4776	-145.966	105.57	0	0	0	0
GND	-62.1398	-154.578	0	7.75119	348.6	7.59809	-1.53294
146	-62.1398	-154.578	4.41917	8.26726	349.	8.11486	-1.58007
147	-62.1398	-154.578	8.83833	8.55621	349.2	8.40484	-1.60232
148	-62.1398	-154.578	13.2575	8.75477	349.4	8.60496	-1.61268
149	-62.1398	-154.578	17.6767	8.87909	349.5	8.73141	-1.61271
150	-62.1398	-154.578	22.0958	8.93646	349.7	8.79148	-1.60316
151	-62.1398	-154.578	26.515	8.93061	349.8	8.78894	-1.58444
152	-62.1398	-154.578	30.9342	8.86397	349.9	8.72617	-1.5569
153	-62.1398	-154.578	35.3533	8.73852	350.	8.60517	-1.52079
154	-62.1398	-154.578	39.7725	8.5559	350.1	8.42756	-1.47642
155	-62.1398	-154.578	44.1917	8.31798	350.1	8.19517	-1.42406
156	-62.1398	-154.578	48.6108	8.0264	350.2	7.90965	-1.36402
157	-62.1398	-154.578	53.03	7.6831	350.3	7.5729	-1.29663
158	-62.1398	-154.578	57.4492	7.29001	350.3	7.18682	-1.22224
159	-62.1398	-154.578	61.8683	6.8492	350.4	6.75346	-1.1412
160	-62.1398	-154.578	66.2875	6.36285	350.5	6.27496	-1.05388
161	-62.1398	-154.578	70.7067	5.83314	350.5	5.75349	-.960666
162	-62.1398	-154.578	75.1258	5.26224	350.6	5.19117	-.861918
163	-62.1398	-154.578	79.545	4.65212	350.6	4.58996	-.757969
164	-62.1398	-154.578	83.9642	4.0044	350.7	3.95144	-.649112
165	-62.1398	-154.578	88.3833	3.31991	350.7	3.27644	-.535486
166	-62.1398	-154.578	92.8025	2.59782	350.8	2.56414	-.416983
167	-62.1398	-154.578	97.2217	1.83349	350.8	1.80995	-.292893
168	-62.1398	-154.578	101.641	1.01232	350.9	.999443	-.16094
END	-62.1398	-154.578	106.06	0	0	0	0
GND	-161.64	-163.342	0	2.91792	240.3	-1.44401	-2.53557
170	-161.64	-163.342	4.31667	3.21352	239.2	-1.64379	-2.76128
171	-161.64	-163.342	8.63333	3.38629	238.6	-1.76259	-2.89142
172	-161.64	-163.342	12.95	3.51417	238.2	-1.85303	-2.98591
173	-161.64	-163.342	17.2667	3.60624	237.8	-1.9213	-3.05181
174	-161.64	-163.342	21.5833	3.66644	237.5	-1.97006	-3.09219
175	-161.64	-163.342	25.9	3.69678	237.2	-2.00066	-3.10862
176	-161.64	-163.342	30.2167	3.69849	237.	-2.01391	-3.10209
177	-161.64	-163.342	34.5333	3.67248	236.8	-2.0104	-3.07334
178	-161.64	-163.342	38.85	3.61951	236.6	-1.99061	-3.02297
179	-161.64	-163.342	43.1667	3.5403	236.5	-1.95498	-2.95157
180	-161.64	-163.342	47.4833	3.43558	236.3	-1.90397	-2.85974
181	-161.64	-163.342	51.8	3.30611	236.2	-1.83805	-2.74808
182	-161.64	-163.342	56.1167	3.15269	236.1	-1.75769	-2.61724
183	-161.64	-163.342	60.4333	2.97615	236.	-1.66341	-2.4679
184	-161.64	-163.342	64.75	2.7774	235.9	-1.55577	-2.30076
185	-161.64	-163.342	69.0667	2.55731	235.9	-1.43531	-2.11653
186	-161.64	-163.342	73.3833	2.31676	235.8	-1.30256	-1.91591
187	-161.64	-163.342	77.7	2.05657	235.7	-1.15806	-1.69952
188	-161.64	-163.342	82.0167	1.77735	235.7	-1.00219	-1.46785
189	-161.64	-163.342	86.3333	1.47939	235.6	-.835177	-1.2211
190	-161.64	-163.342	90.65	1.16222	235.6	-.656808	-.958826
191	-161.64	-163.342	94.9667	.823604	235.6	-.465874	-.679179
192	-161.64	-163.342	99.2833	.456799	235.5	-.258599	-.376553
END	-161.64	-163.342	103.6	0	0	0	0

APPENDIX D

DETUNE MODEL

**APPENDIX D – DETUNE MODEL
STATION KBME – HOUSTON, TEXAS**

ELECTRICAL DESCRIPTION -TOWER #3 DETUNE

Frequencies (MHz)

frequency		no. of steps	segment length (wavelengths)	
no. lowest	step		minimum	maximum
1	.79	0	.0122072	.0122072

Plane wave source

zenith angle (deg)	=	90
increment (deg)	=	0
number of angles	=	1
azimuth angle (deg)	=	0
increment (deg)	=	0
number of angles	=	1
polarization angle (deg)	=	0
magnitude (v/m)	=	1

Lumped loads

load	node	resistance (ohms)	reactance (ohms)	inductance (mH)	capacitance (uF)	passive circuit
1	1	.01	0	.09	0	0

GEOMETRY - TOWER #3 DETUNE

Wire coordinates in degrees; other dimensions in meters

Environment: perfect ground

wire	caps	Distance	Angle	Z	radius	segs
1	none	0	0	0	.2911	24
		0	0	105.47		

Number of wires = 1
current nodes = 24

Individual wires	minimum		maximum	
	wire	value	wire	value
segment length	1	4.39458	1	4.39458
radius	1	.2911	1	.2911

RMS CURRENTS - TOWER #3 DETUNE

Frequency = .79 MHz

Plane wave zenith (deg) = 90

Plane wave azimuth (deg) = 0

Polarization angle (deg) = 0

coordinates in degrees

current				mag	phase	real	imaginary
no.	X	Y	Z	(amps)	(deg)	(amps)	(amps)
GND	0	0	0	.224666	270.2	8.85E-04	-.224664
2	0	0	4.39458	.174116	270.2	6.88E-04	-.174114
3	0	0	8.78917	.140812	270.2	5.59E-04	-.14081
4	0	0	13.1838	.111906	270.2	4.48E-04	-.111905
5	0	0	17.5783	.0859213	270.2	3.49E-04	-.0859205
6	0	0	21.9729	.0622583	270.2	2.61E-04	-.0622577
7	0	0	26.3675	.0406586	270.3	1.81E-04	-.0406582
8	0	0	30.7621	.0210062	270.3	1.09E-04	-.0210059
9	0	0	35.1567	3.26E-03	270.8	4.56E-05	-3.26E-03
10	0	0	39.5513	.0126005	90.	-1.04E-05	.0126005
11	0	0	43.9458	.0265497	90.1	-5.87E-05	.0265496
12	0	0	48.3404	.0385684	90.1	-9.96E-05	.0385682
13	0	0	52.735	.048628	90.2	-1.33E-04	.0486278
14	0	0	57.1296	.0566981	90.2	-1.59E-04	.0566979

15	0	0	61.5242	.0627491	90.2	-1.78E-04	.0627488
16	0	0	65.9188	.0667522	90.2	-1.9E-04	.0667519
17	0	0	70.3133	.0686809	90.2	-1.96E-04	.0686806
18	0	0	74.7079	.0685086	90.2	-1.94E-04	.0685083
19	0	0	79.1025	.0662075	90.2	-1.86E-04	.0662072
20	0	0	83.4971	.0617431	90.2	-1.72E-04	.0617429
21	0	0	87.8917	.0550655	90.2	-1.52E-04	.0550653
22	0	0	92.2863	.0460885	90.2	-1.25E-04	.0460883
23	0	0	96.6808	.0346377	90.2	-9.27E-05	.0346376
24	0	0	101.075	.0203073	90.2	-5.35E-05	.0203073
END	0	0	105.47	0	0	0	0

ELECTRICAL DESCRIPTION - TOWER #4 DETUNE

Frequencies (MHz)

frequency		no. of steps	segment length (wavelengths)	
no. lowest	step		minimum	maximum
1	.79	0	.0117882	.0117882

Plane wave source

zenith angle (deg)	=	90
increment (deg)	=	0
number of angles	=	1
azimuth angle (deg)	=	0
increment (deg)	=	0
number of angles	=	1
polarization angle (deg)	=	0
magnitude (v/m)	=	1

Lumped loads

load	node	resistance (ohms)	reactance (ohms)	inductance (mH)	capacitance (uF)	passive circuit
1	1	.01	0	.094	0	0

GEOMETRY - TOWER #4 DETUNE

Wire coordinates in degrees; other dimensions in meters

Environment: perfect ground

wire	caps	Distance	Angle	Z	radius	segs
1	none	0	0	0	.2911	24
		0	0	101.85		

Number of wires = 1
current nodes = 24

	minimum	maximum
Individual wires	wire	value
segment length	1	4.24375
radius	1	.2911

**APPENDIX D – DETUNE MODEL
STATION KBME – HOUSTON, TEXAS**

RMS CURRENTS - TOWER #4 DETUNE

Frequency = .79 MHz
Plane wave zenith (deg) = 90
Plane wave azimuth (deg) = 0
Polarization angle (deg) = 0
coordinates in degrees

current				mag	phase	real	imaginary
no.	X	Y	Z	(amps)	(deg)	(amps)	(amps)
GND	0	0	0	.209411	270.1	5.11E-04	-.20941
2	0	0	4.24375	.161246	270.1	3.95E-04	-.161246
3	0	0	8.4875	.12977	270.1	3.2E-04	-.12977
4	0	0	12.7313	.102537	270.1	2.55E-04	-.102537
5	0	0	16.975	.0781306	270.1	1.98E-04	-.0781304
6	0	0	21.2188	.0559668	270.2	1.47E-04	-.0559666
7	0	0	25.4625	.0357884	270.2	1.02E-04	-.0357882
8	0	0	29.7063	.0174748	270.2	6.08E-05	-.0174747
9	0	0	33.95	9.74E-04	271.4	2.46E-05	-9.74E-04
10	0	0	38.1938	.0137309	90.	-7.03E-06	.0137309
11	0	0	42.4375	.0266343	90.1	-3.42E-05	.0266342
12	0	0	46.6813	.0377214	90.1	-5.71E-05	.0377213
13	0	0	50.925	.046971	90.1	-7.57E-05	.0469709
14	0	0	55.1688	.0543598	90.1	-9.01E-05	.0543598
15	0	0	59.4125	.059864	90.1	-1.E-04	.0598639
16	0	0	63.6563	.0634601	90.1	-1.07E-04	.06346
17	0	0	67.9	.0651254	90.1	-1.09E-04	.0651253
18	0	0	72.1438	.0648367	90.1	-1.08E-04	.0648366
19	0	0	76.3875	.0625684	90.1	-1.03E-04	.0625683
20	0	0	80.6313	.058288	90.1	-9.52E-05	.0582879
21	0	0	84.875	.0519469	90.1	-8.36E-05	.0519468
22	0	0	89.1188	.0434617	90.1	-6.89E-05	.0434616
23	0	0	93.3625	.0326642	90.1	-5.09E-05	.0326642
24	0	0	97.6063	.0191675	90.1	-2.93E-05	.0191675
END	0	0	101.85	0	0	0	0

ELECTRICAL DESCRIPTION - TOWER #5 DETUNE

Frequencies (MHz)

no.	frequency	step	no. of steps	segment length (wavelengths)
	lowest			minimum maximum
1	.79	0	1	.0119456 .0119456

Plane wave source

zenith angle (deg) = 90
increment (deg) = 0
number of angles = 1
azimuth angle (deg) = 0
increment (deg) = 0
number of angles = 1
polarization angle (deg) = 0
magnitude (v/m) = 1

Lumped loads

load	node	resistance (ohms)	reactance (ohms)	inductance (mH)	capacitance (uF)	passive circuit
1	1	.01	0	.098	0	0

**APPENDIX D – DETUNE MODEL
STATION KBME – HOUSTON, TEXAS**

GEOMETRY - TOWER #5 DETUNE

Wire coordinates in degrees; other dimensions in meters
Environment: perfect ground

wire	caps	Distance	Angle	Z	radius	segs
1	none	0	0	0	.2358	24
		0	0	103.21		

Number of wires = 1
current nodes = 24

	minimum		maximum	
Individual wires	wire	value	wire	value
segment length	1	4.30042	1	4.30042
radius	1	.2358	1	.2358

RMS CURRENTS - TOWER #5 DETUNE

Frequency = .79 MHz
Plane wave zenith (deg) = 90
Plane wave azimuth (deg) = 0
Polarization angle (deg) = 0

coordinates in degrees

current	coordinates in degrees			mag	phase	real	imaginary
no.	X	Y	Z	(amps)	(deg)	(amps)	(amps)
GND	0	0	0	.20286	270.1	4.98E-04	-.20286
2	0	0	4.30042	.157689	270.1	3.88E-04	-.157688
3	0	0	8.60083	.127171	270.1	3.15E-04	-.12717
4	0	0	12.9013	.100649	270.1	2.52E-04	-.100649
5	0	0	17.2017	.0767949	270.1	1.96E-04	-.0767946
6	0	0	21.5021	.0550812	270.2	1.46E-04	-.055081
7	0	0	25.8025	.0352778	270.2	1.01E-04	-.0352777
8	0	0	30.1029	.0172813	270.2	6.06E-05	-.0172812
9	0	0	34.4033	1.05E-03	271.4	2.49E-05	-1.05E-03
10	0	0	38.7038	.0134236	90.	-6.26E-06	.0134236
11	0	0	43.0042	.0261301	90.1	-3.31E-05	.0261301
12	0	0	47.3046	.0370499	90.1	-5.56E-05	.0370499
13	0	0	51.605	.0461588	90.1	-7.39E-05	.0461587
14	0	0	55.9054	.0534311	90.1	-8.81E-05	.053431
15	0	0	60.2058	.0588416	90.1	-9.82E-05	.0588415
16	0	0	64.5063	.0623659	90.1	-1.04E-04	.0623658
17	0	0	68.8067	.0639813	90.1	-1.07E-04	.0639812
18	0	0	73.1071	.0636653	90.1	-1.06E-04	.0636652
19	0	0	77.4075	.0613936	90.1	-1.01E-04	.0613935
20	0	0	81.7079	.0571364	90.1	-9.27E-05	.0571363
21	0	0	86.0083	.0508494	90.1	-8.13E-05	.0508493
22	0	0	90.3088	.0424565	90.1	-6.68E-05	.0424565
23	0	0	94.6092	.0318032	90.1	-4.91E-05	.0318031
24	0	0	98.9096	.0185221	90.1	-2.8E-05	.0185221
END	0	0	103.21	0	0	0	0

**APPENDIX D – DETUNE MODEL
STATION KBME – HOUSTON, TEXAS**

ELECTRICAL DESCRIPTION - TOWER #6 DETUNE

Frequencies (MHz)

no.	lowest	step	no. of steps	segment length (wavelengths) minimum	maximum
1	.79	0	1	.0122188	.0122188

Plane wave source

zenith angle (deg)	=	90
increment (deg)	=	0
number of angles	=	1
azimuth angle (deg)	=	0
increment (deg)	=	0
number of angles	=	1
polarization angle (deg)	=	0
magnitude (v/m)	=	1

Lumped loads

load	node	resistance (ohms)	reactance (ohms)	inductance (mH)	capacitance (uF)	passive circuit
1	1	1.E-03	0	.09	0	0

GEOMETRY - TOWER #6 DETUNE

Wire coordinates in degrees; other dimensions in meters
Environment: perfect ground

wire	caps	Distance	Angle	Z	radius	segs
1	none	0	0	0	.2911	24
		0	0	105.57		

Number of wires = 1
current nodes = 24

Individual wires	minimum		maximum	
	wire	value	wire	value
segment length	1	4.39875	1	4.39875
radius	1	.2911	1	.2911

RMS CURRENTS - TOWER #6 DETUNE

Frequency = .79 MHz
Plane wave zenith (deg) = 90
Plane wave azimuth (deg) = 0
Polarization angle (deg) = 0
coordinates in degrees

current no.	X	Y	Z	mag (amps)	phase (deg)	real (amps)	imaginary (amps)
GND	0	0	0	.224885	270.2	8.63E-04	-.224883
2	0	0	4.39875	.174256	270.2	6.7E-04	-.174255
3	0	0	8.7975	.140894	270.2	5.43E-04	-.140893
4	0	0	13.1963	.111938	270.2	4.34E-04	-.111937
5	0	0	17.595	.0859057	270.2	3.38E-04	-.085905
6	0	0	21.9938	.0622	270.2	2.51E-04	-.0621995
7	0	0	26.3925	.040561	270.2	1.73E-04	-.0405606
8	0	0	30.7913	.0208731	270.3	1.03E-04	-.0208728
9	0	0	35.19	3.09E-03	270.8	4.07E-05	-3.09E-03
10	0	0	39.5888	.0127926	90.1	-1.4E-05	.0127926
11	0	0	43.9875	.0267648	90.1	-6.12E-05	.0267648
12	0	0	48.3863	.038802	90.1	-1.01E-04	.0388019
13	0	0	52.785	.0488753	90.2	-1.34E-04	.0488751
14	0	0	57.1838	.0569543	90.2	-1.59E-04	.0569541

**APPENDIX D – DETUNE MODEL
STATION KBME – HOUSTON, TEXAS**

15	0	0	61.5825	.0630091	90.2	-1.77E-04	.0630088
16	0	0	65.9813	.0670109	90.2	-1.89E-04	.0670107
17	0	0	70.38	.0689331	90.2	-1.94E-04	.0689329
18	0	0	74.7788	.0687492	90.2	-1.92E-04	.068749
19	0	0	79.1775	.0664312	90.2	-1.84E-04	.066431
20	0	0	83.5763	.0619448	90.2	-1.69E-04	.0619446
21	0	0	87.975	.0552398	90.2	-1.49E-04	.0552396
22	0	0	92.3738	.0462301	90.2	-1.23E-04	.0462299
23	0	0	96.7725	.034741	90.2	-9.12E-05	.0347409
24	0	0	101.171	.0203657	90.1	-5.25E-05	.0203657
END	0	0	105.57	0	0	0	0